

Analog Devices Driver Help

© 2011 Kepware Technologies

Table of Contents

Table of Contents	2
Analog Devices Driver Help	3
Overview	3
Driver Setup	4
Device Setup	5
Data Format	5
Modem Setup	6
Data Types Description	7
Address Descriptions	8
6B11 Addresses	8
6B12 Addresses	8
6B13 Addresses	8
6B21 Addresses	8
6B50 Addresses	8
Error Descriptions	10
Address Validation	10
Missing address	10
Device address '<address>' contains a syntax error	10
Address '<address>' is out of range for the specified device or register	10
Device address '<address>' is not supported by model '<model name>'	11
Data Type '<type>' is not valid for device address '<address>'	11
Device address '<address>' is Read Only	11
Serial Communications	11
COMn does not exist	11
Error opening COMn	12
COMn is in use by another application	12
Unable to set comm parameters on COMn	12
Communications error on '<channel name>' [<error mask>]	12
Device Status Messages	12
Device '<device name>' is not responding	13
Unable to write to '<address>' on device '<device name>'	13
Device Specific Messages	13
Value out of range writing to address '<address>' on device '<device name>'	13
Index	14

Analog Devices Driver Help

Help version 1.014

CONTENTS

[Overview](#)

What is the Analog Devices Driver?

[Driver Setup](#)

How do I configure the driver to communicate with a network of 6B Series devices?

[Device Setup](#)

How do I configure a device for use with this driver?

[Data Types Description](#)

What data types does this driver support?

[Address Descriptions](#)

How do I address a data location on an Analog Devices driver?

[Error Descriptions](#)

What error messages does this driver produce?

Overview

The Analog Devices Driver provides an easy and reliable way to connect the Analog Devices devices to OPC Client applications, including HMI, SCADA, Historian, MES, ERP and countless custom applications. It is intended for use with Analog Devices devices.

Driver Setup

Protocol

The **Use Checksum** parameter should be checked when the device has been configured to use checksum verification. All devices must have the same checksum parameters. Checksum verification is disabled by default.

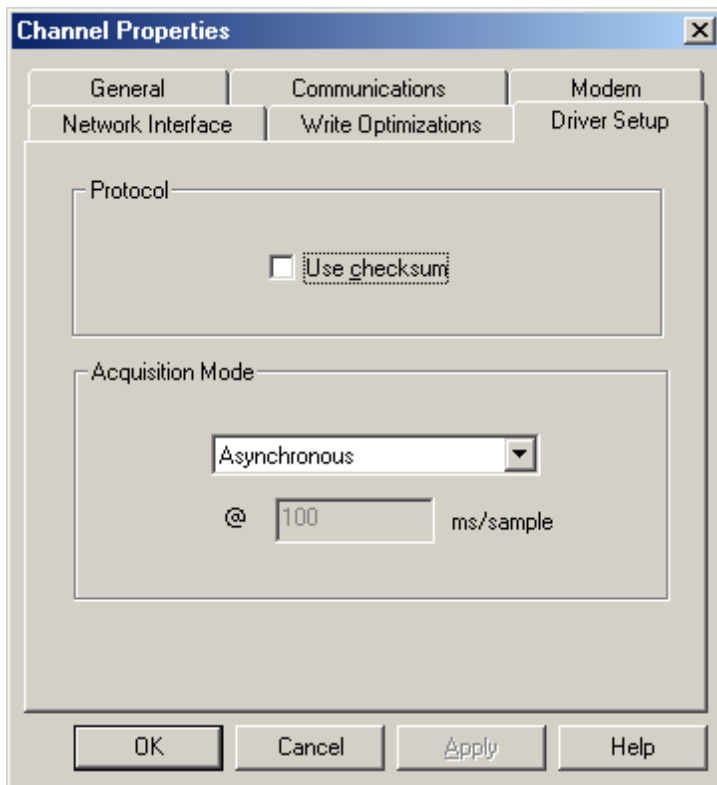

Acquisition Mode

This parameter is used to select the Acquisition Mode. Descriptions of the modes are as follows:

- **Asynchronous:** This setting should be selected if users do not require synchronously sampled data from all network devices.
- **Synchronous:** This setting should be selected in order to have the driver issue a synchronous sample command to all devices at the interval specified in the @__ **ms/sample** control. When synchronous data is sampled, the client application will receive an update as soon as it is available, rather than on the interval specified by the scan time of the tag to which the data is assigned. When selected, this setting may have the flow of data from sources other than synchronous sampling disrupted while devices on the network are sampling their inputs.

Note: Valid synchronous sampling intervals range from 100 to 86400000 ms in increments of 10 ms. A minimum amount of time will be required to obtain the data from all devices. If users have 10 or more devices connected, they will be unable to obtain a sample from each device within 100 ms if the serial communications rate is 9600 baud (or less.)

Device Setup

Supported Devices

6B11, 6B12 and 6B13 Analog Input modules
 6B21 Analog Output module
 6B50 Digital I/O module

Communication Protocol

RS232
 ASCII with optional checksum

Supported Communication Parameters

Baud Rate: 300, 600, 1200, 2400, 9600, or 19200
 Parity: None
 Data Bits: 8
 Stop Bits: 1

Ethernet Encapsulation

This driver supports Ethernet Encapsulation, which allows the driver to communicate with serial devices attached to an Ethernet network using a terminal server. It may be invoked through the COM ID dialog in Channel Properties. For more information, refer to the main OPC Server help file.

Device IDs

Device IDs range from 0 to 255.

Flow Control

The Analog Devices driver does not normally require flow control since the 6B back plane features a built-in RS-485 converter. This information is provided for reference.

When using an RS232/RS485 converter, the type of flow control that is required will depend on the needs of the converter. Some converters do not require any flow control whereas others will require RTS flow. Consult the converter's documentation in order to determine its flow requirements. An RS485 converter that provides automatic flow control is recommended.

Note: When using the manufacturer's supplied communications cable, it is sometimes necessary to choose a flow control setting of **RTS** or **RTS Always** under the Channel Properties.

Cable Connections

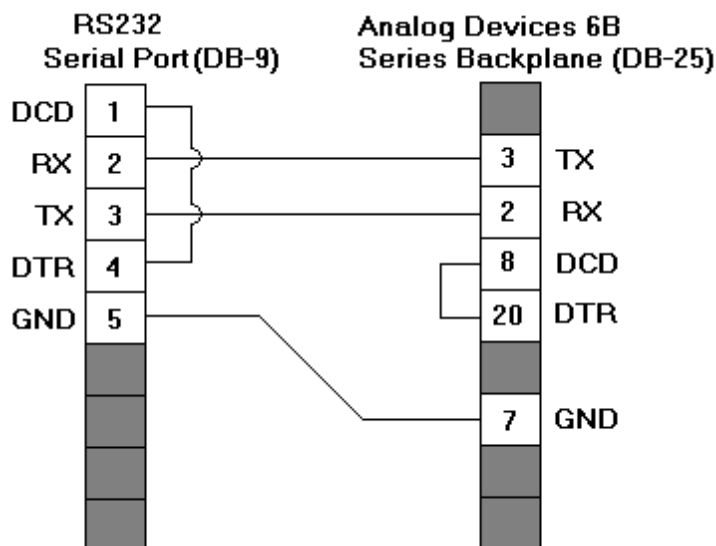

Data Format

The Data Format selected for each module must match the format chosen when the device was last configured. Options include Engineering Units, Percent of FSR and Twos Complement Hex.

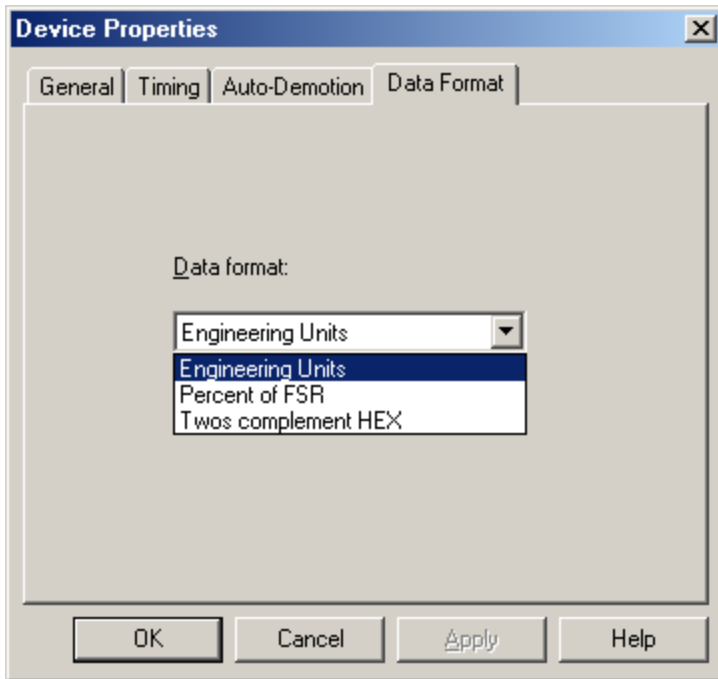

Note: This driver provides no configuration options.

Modem Setup

This driver supports modem functionality. For more information, please refer to the topic "Modem Support" in the OPC Server Help documentation.

Data Types Description

It is important that the correct data type be chosen when defining a tag for a specific piece of data. Because each device can be configured to output data in either integer or Floating-point format, care should be taken to match the selected data type with the data format. When defining tags dynamically, the default data type will be chosen based on the data format for the device where applicable.

Data Type	Description
Boolean	Single bit
Byte	Unsigned 8 bit value bit 0 is the low bit bit 7 is the high bit
Char	Signed 8 bit value bit 0 is the low bit bit 6 is the high bit bit 7 is the sign bit
Word	Unsigned 16 bit value bit 0 is the low bit bit 15 is the high bit
Short	Signed 16 bit value bit 0 is the low bit bit 14 is the high bit bit 15 is the sign bit
Double	64 bit double precision Floating point value.
Float	32 bit single precision Floating point value.

Address Descriptions

Address specifications vary depending on the module in use. Select a link from the following list to obtain specific address information for the module of interest.

[6B11 Addresses](#)

[6B12 Addresses](#)

[6B13 Addresses](#)

[6B21 Addresses](#)

[6B50 Addresses](#)

6B11 Addresses

The default data types for dynamically defined tags are shown in **bold**.

Address Type	Specification	Valid Data Types*	Access
Input Value	IV	Float , Double (EU and %FSR) Short , Word (2's Comp.)	Read Only
CJC Status	CJC	Float , Double	Read Only
Synchronous Data	SD	Float , Double (EU and %FSR) Short , Word (2's Comp.)	Read Only

*The valid data types depend on the data format that was selected for the device.

6B12 Addresses

The default data types for dynamically defined tags are shown in **bold**.

Address Type	Specification	Valid Data Types*	Access
Input Value	IV	Float , Double (EU and %FSR) Short , Word (2's Comp.)	Read Only
Synchronous Data	SD	Float , Double (EU and %FSR) Short , Word (2's Comp.)	Read Only

*The valid data types depend on the data format that was selected for the device.

6B13 Addresses

The default data types for dynamically defined tags are shown in **bold**.

Address Type	Specification	Valid Data Types*	Access
Input Value	IV	Float , Double (EU, %FSR and Ohms) Short , Word (2's Comp.)	Read Only

*The valid data types depend on the data format that was selected for the device.

6B21 Addresses

The default data types for dynamically defined tags are shown in **bold**.

Address Type	Specification	Valid Data Types*	Access
Output Value	OV	Float , Double (EU and %Span) Short , Word (Hexadecimal)	Read/Write
Current Readback	CR	Float , Double (EU and %Span) Short , Word (Hexadecimal)	Read Only
Reset Status	RS	Boolean	Read Only

*The valid data types depend on the data format that was selected for the device.

6B50 Addresses

The default data types for dynamically defined tags are shown in **bold**.

Address Type	Specification	Valid Data Types*	Access
Port Data	DA DB DC	Byte , Char	Read/Write
Channel Data	DA.<Channel> DB.<Channel> DC.<Channel>	Boolean	Read/Write
Sync. Port Data**	SDA SDB SDC	Byte , Char	Read Only
Sync. Channel Data**	SDA.<Channel> SDB.<Channel> SDC.<Channel>	Boolean	Read Only
Reset Status	RS	Boolean	Read Only

*The valid data types depend on the data format that was selected for the device.

**These address types are only valid if synchronous acquisition mode is enabled. For more information, refer to [Driver Setup](#).

Error Descriptions

The following error/warning messages may be generated. Click on the link for a description of the message.

Address Validation

[Missing address](#)

[Device address '<address>' contains a syntax error](#)

[Address '<address>' is out of range for the specified device or register](#)

[Device address '<address>' is not supported by model '<model name>'](#)

[Data Type '<type>' is not valid for device address '<address>'](#)

[Device address '<address>' is Read Only](#)

Serial Communications

[COMn does not exist](#)

[Error opening COMn](#)

[COMn is in use by another application](#)

[Unable to set comm parameters on COMn](#)

[Communications error on '<channel name>' \[<error mask>\]](#)

Device Status Messages

[Device '<device name>' is not responding](#)

[Unable to write to '<address>' on device '<device name>'](#)

Device Specific Messages

[Value out of range writing to address '<address>' on device '<device name>'](#)

Address Validation

The following error/warning messages may be generated. Click on the link for a description of the message.

Address Validation

[Missing address](#)

[Device address '<address>' contains a syntax error](#)

[Address '<address>' is out of range for the specified device or register](#)

[Device address '<address>' is not supported by model '<model name>'](#)

[Data Type '<type>' is not valid for device address '<address>'](#)

[Device address '<address>' is Read Only](#)

Missing address

Error Type:

Warning

Possible Cause:

A tag address that has been specified dynamically has no length.

Solution:

Re-enter the address in the client application.

Device address '<address>' contains a syntax error

Error Type:

Warning

Possible Cause:

A tag address that has been specified dynamically contains one or more invalid characters.

Solution:

Re-enter the address in the client application.

Address '<address>' is out of range for the specified device or register

Error Type:

Warning

Possible Cause:

A tag address that has been specified dynamically references a location that is beyond the range of supported locations for the device.

Solution:

Verify that the address is correct; if it is not, re-enter it in the client application.

Device address '<address>' is not supported by model '<model name>'

Error Type:

Warning

Possible Cause:

A tag address that has been specified dynamically references a location that is valid for the communications protocol but not supported by the target device.

Solution:

Verify that the address is correct; if it is not, re-enter it in the client application. Also verify that the selected model name for the device is correct.

Data Type '<type>' is not valid for device address '<address>'

Error Type:

Warning

Possible Cause:

A tag address that has been specified dynamically has been assigned an invalid data type.

Solution:

Modify the requested data type in the client application.

Device address '<address>' is Read Only

Error Type:

Warning

Possible Cause:

A tag address that has been specified dynamically has a requested access mode that is not compatible with what the device supports for that address.

Solution:

Change the access mode in the client application.

Serial Communications

The following error/warning messages may be generated. Click on the link for a description of the message.

Serial Communications

[COMn does not exist](#)

[Error opening COMn](#)

[COMn is in use by another application](#)

[Unable to set comm parameters on COMn](#)

[Communications error on '<channel name>' \[<error mask>\]](#)

COMn does not exist

Error Type:

Fatal

Possible Cause:

The specified COM port is not present on the target computer.

Solution:

Verify that the proper COM port has been selected.

Error opening COMn

Error Type:

Fatal

Possible Cause:

The specified COM port could not be opened due an internal hardware or software problem on the target computer.

Solution:

Verify that the COM port is functional and may be accessed by other Windows applications.

COMn is in use by another application

Error Type:

Fatal

Possible Cause:

The serial port assigned to a device is being used by another application.

Solution:

Verify that the correct port has been assigned to the channel.

Unable to set comm parameters on COMn

Error Type:

Fatal

Possible Cause:

The serial parameters for the specified COM port are not valid.

Solution:

Verify the serial parameters and make any necessary changes.

Communications error on '<channel name>' [<error mask>]

Error Type:

Serious

Error Mask Definitions:

B = Hardware break detected.

F = Framing error.

E = I/O error.

O = Character buffer overrun.

R = RX buffer overrun.

P = Received byte parity error.

T = TX buffer full.

Possible Cause:

1. The serial connection between the device and the Host PC is bad.
2. The communications parameters for the serial connection are incorrect.

Solution:

1. Verify the cabling between the PC and the device.
2. Verify that the specified communications parameters match those of the device.

Device Status Messages

The following error/warning messages may be generated. Click on the link for a description of the message.

Device Status Messages

[Device '<device name>' is not responding](#)

[Unable to write to '<address>' on device '<device name>'](#)

Device '<device name>' is not responding

Error Type:

Serious

Possible Cause:

1. The serial connection between the device and the Host PC is broken.
2. The communications parameters for the serial connection are incorrect.
3. The named device may have been assigned an incorrect Network ID.

Solution:

1. Verify the cabling between the PC and the device.
2. Verify the specified communications parameters match those of the device.
3. Verify the Network ID given to the named device matches that of the actual device.

Unable to write to '<address>' on device '<device name>'

Error Type:

Serious

Possible Cause:

1. The serial connection between the device and the Host PC is broken.
2. The communications parameters for the serial connection are incorrect.
3. The named device may have been assigned an incorrect Network ID.

Solution:

1. Verify the cabling between the PC and the device.
2. Verify the specified communications parameters match those of the device.
3. Verify the Network ID given to the named device matches that of the actual device.

Device Specific Messages

The following error/warning messages may be generated. Click on the link for a description of the message.

Device Specific Messages

[Value out of range writing to address '<address>' on device '<device name>'](#)

Value out of range writing to address '<address>' on device '<device name>'

Error Type:

Warning

Possible Cause:

The value that is being attempted to write is not within the range of valid input for the specified address.

Solution:

Verify that the device is configured for the proper data range.

Index

6

6B11 Addresses.....	8
6B12 Addresses.....	8
6B13 Addresses.....	8
6B21 Addresses.....	8
6B50 Addresses.....	8

A

Acquisition.....	4
Address '<address>' is out of range for the specified device or register.....	10
Address Descriptions.....	8
Address Validation.....	10

B

Boolean.....	7
--------------	---

C

Communications error on '<channel name>' [<error mask>].....	12
COMn does not exist.....	11
COMn is in use by another application.....	12

D

Data Format.....	5
Data Type '<type>' is not valid for device address '<address>'.....	11
Data Types Description.....	7
Device '<device name>' is not responding.....	13
Device address '<address>' contains a syntax error.....	10
Device address '<address>' is not supported by model '<model name>'.....	11
Device address '<address>' is read only.....	11
Device ID.....	5
Device Setup.....	5
Device Specific Messages.....	13
Device Status Messages.....	12
Double.....	7
Driver Setup.....	4

E

Error Descriptions.....	10
Error opening COMn.....	12

F

Float	7
Framing.....	12

M

Mask	12
Missing address	10
Modem Setup.....	6

N

Network.....	5
--------------	---

O

Overrun.....	12
Overview.....	3

P

Parity.....	12
-------------	----

S

Serial Communications.....	11
Short	7
Synchronized	4

U

Unable to set comm parameters on COMn.....	12
Unable to write tag '<address>' on device '<device name>'.....	13

V

Value out of range writing to address '<address>' on device '<device name>'.....	13
----------------------------------------------------------------------------------	----

W

Word.....	7
-----------	---