



Siemens S7-200 Addressing

V4.x 10/1/01 Document v1.01

Overview

The purpose of this document is to explain addressing in the Siemens S7-200 PLC's as referenced by the Kepware driver vs. the Simatic S7-200 User manual.

Getting all the Data all the Time

Siemens Addressing*

In the Siemens S7-200 Reference Manual and the programming software, you can access data in many CPU memory areas (V, I, Q, M, S, L, and SM) as bytes, words, or double words by using their byte-address format. To access a byte, word, or double word of data in the CPU memory, you must

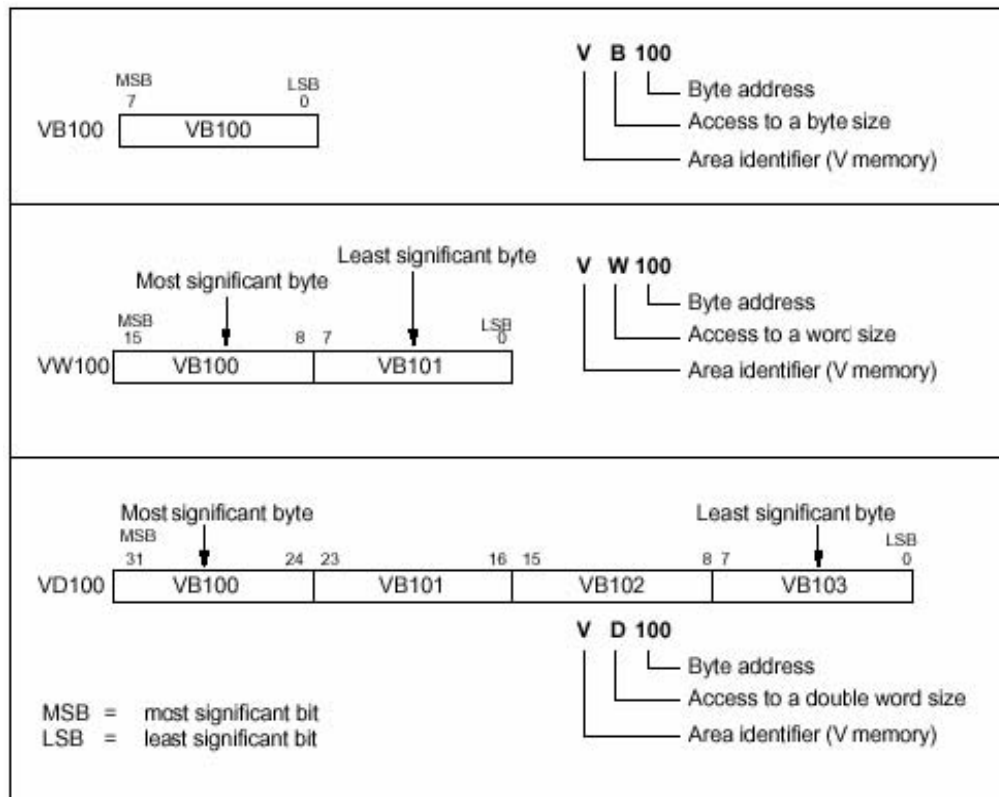

In Siemens formatting each additional address will use its starting byte address for example if you were going to look at V memory and they were 5 data references consisting of 1 word, 2 bytes, and 1 dword the address references might be listed as follows: VW100, VB102, VB103, and VD104.

Kepware Addressing*

In Kepware's S7-200 driver you will see that we actual format our data the same way as Siemens does. The Only difference is that we use a separate Data type field to indicate the size of the data.

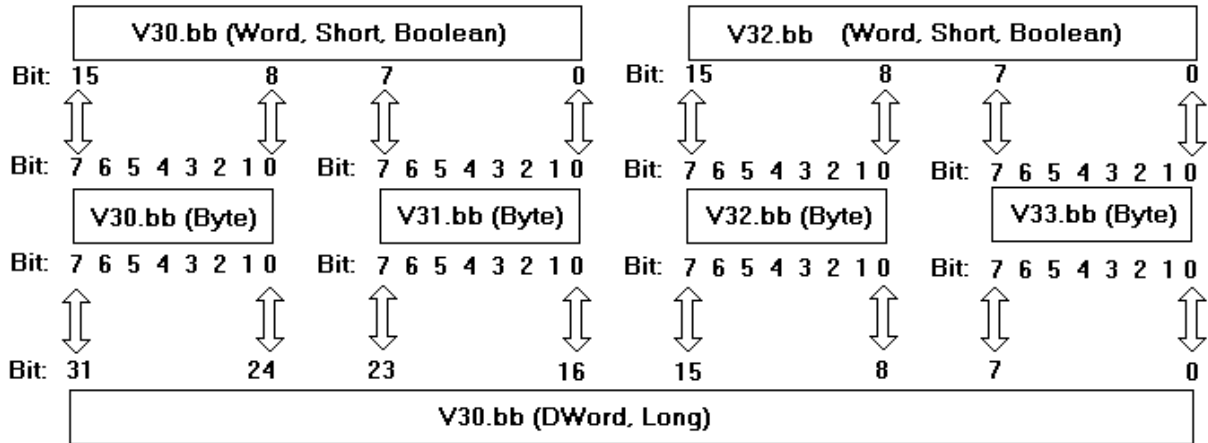

So in the KEPServerEX if we were going to look at V memory addresses and they were 5 data references consisting of 1 word, 2 bytes, and 1 dword the address references might be listed as follows: V100 data type of word, V102 data type of byte, V103 data type of byte, and V104 data type of dword.

If you were adding those items to the server dynamically from your software client then you would append the data type to the address so that the default data type may be overridden. Details on the data types available to each memory location can be found in the driver help file. To learn more about dynamically adding tags to a server project look in the "How Do I" section of the Server Help File.

* Although both examples use the V memory locations for examples, this formatting is used by the I, Q, M, S, L, and SM memory locations as well.