

DNP3 Master Serial Driver Help

© 2015 Kepware, Inc.

Table of Contents

Table of Contents	2
DNP3 Master Serial Driver Help	8
Overview	8
Channel Setup	9
Timing	9
Device Setup	10
Communications	10
Polling	13
Unsolicited Messaging	14
Event Playback	15
Tag Import	16
Authentication	17
File Control	19
Advanced	21
Timing and Other Considerations	22
Modem Setup	23
Data Types Description	24
Address Descriptions	25
Object Group 0 - Device Attributes	27
Object Group 1 - Binary Inputs	28
Object Group 3 - Double-Bit Inputs	30
Object Group 10 - Binary Outputs	31
Object Group 12 - Binary Output Commands	33
Object Group 20 - Counters	35
Object Group 21 - Frozen Counters	36
Object Group 30 - Analog Inputs	37
Object Group 34 - Analog Inputs Deadband	39
Object Group 40 - Analog Outputs	40
Object Group 41 - Analog Output Commands	42
Object Group 50 - Time and Date	42
Object Group 60 - Class Poll Data Request	43
Object Group 70 - File Identifiers	44
Object Group 80 - Internal	44
Object Group 87 - Data Sets	45
Object Group 110 - Octet String Object	46
Object Group 120 - Authentication Object	47
Other Object Groups	48
Internal Tags	49
Special Tags	50
Error Descriptions	51

Address Validation	51
Address <address> is not valid on device <channel> <device>.	51
Address <address> is out of range for the specified device or register.	51
Data type <type> is not valid for device address <address>.	51
Device address <address> contains a syntax error.	51
Device address <address> is read only.	52
Authentication Error Messages	52
Secure authentication failure on device <channel.device>. Device does not support the function code (IIN2.0).	52
Secure authentication failure on device <channel.device>. Key Status Request communications failure. Session keys are not valid.	52
Secure authentication failure on device <channel.device>. Key Status Request non-authentic. Session keys are not valid.	53
Secure authentication failure on device <channel.device>. Aggressive Mode response indicates improper authentication.	53
Secure authentication failure on device <channel.device>. Challenge Reply indicates improper authentication.	53
Secure authentication failure on device <channel.device>. User= <user number>, AssocID= <Association ID>, Sequence= <sequence number>. RX Error Code= <error code>-<error description>.	53
Secure authentication failure on device <channel.device>. User= <user number>, AssocID= <Association ID>, Sequence= <sequence number>. TX Error Code= <error code>-<error description>.	54
Secure authentication failure on device <device>. Key Status Request response status code: <status code>.	55
Automatic Tag Database Generation Messages	55
Unable to add data set <data set index> on device <device name>. Data set has <number of elements> elements. The maximum number of elements allowed is <max. elements>.	55
Unable to generate a tag database for device <device>. Channel is not open.	55
Unable to generate a tag database for device <device>. Session is not open.	55
Unable to generate a tag database for device <device name>. Unable to open communications port. ...	56
Unable to generate a tag database for device <driver>. The device is not responding.	56
Unable to read device attribute set <set number>. No tags added on device <device>.	56
Device Status Messages	56
<item description> on device <device> has been auto-demoted.	57
<item description> on device <device> has been auto-promoted to determine if it can be completed. ...	57
Added <tag count> data set tag(s).	58
Data set write of value <value to be written> pending on tag address <address> on device <device>. ...	58
Device <device> does not support the LAN Time Sync Style Record Current Time Function Code 24. ...	58
Device <device> does not support the LAN Time Sync Style write to object group 50, variation 3.	58
Device <device> indicated an event buffer overflow (IIN 2.3).	59
Device <device> indicated it restarted (IIN 1.7).	59
Device <device> initialization completed.	59
Device <device> requested time synchronization (IIN 1.4).	60
Device <device> restarting.	60
Device <device name> is not responding.	60
Reached Max. Events Per Point for object group <object group> Point <data index> on device <device>.	60

Request failed on device <device>. Device does not support the function code (IIN2.0).	61
Request to enable unsolicited messaging failed on device <device>.	61
Unable to bind to local address (IP: xxx.xxx.xxx.xxx, Source Port: x).	62
Unable to read point(s) <OBJ.VAR.IDX> on device <device>. Failed to initialize communication stack.	62
Unable to read point(s) <OBJ.VAR.IDX> on device <device>. Internal error occurred.	62
Unable to read point(s) <OBJ.VAR.IDX – OBJ.VAR.IDX> on device <device>. Failed to initialize communication stack.	62
Unable to read point(s) <OBJ.VAR.IDX – OBJ.VAR.IDX> on device <device>. Internal error occurred.	62
Unable to read tag <tag address> on device <device>. Device indicates one or more exception conditions (DNP flags byte=<hexadecimal byte> - <DNP flag exception list>).	63
Unable to receive response from device <device> within timeout. Either the request or response could not be completed or the response is invalid.	63
Unable to write to address <address> on device <device>. Failed to initialize communication stack.	64
Unable to write to address <address> on device <device>. Internal error occurred.	64
Write complete to data set <index> on device <device>.	64
DNP Specific Error Messages	64
Read Errors	64
The returned value for tag address <tag address> in device <device name> has a length of zero. The tag value cannot be set.	66
The returned value of <date returned value> for tag address <address> in device <device> is invalid for the <data type> tag data type.	66
The returned value of <returned numeric value> for tag address <address> in device <device> is invalid for the <data type> tag data type.	66
The returned value of <returned numeric value> for tag address <address> in device <device> is out of range for the <data type> tag data type.	66
The returned value of <returned string value> for tag address <address> in device <device> is invalid for the <data type> tag data type.	66
Unable to read point(s) <OBJ.VAR.IDX> on device <device>. An abnormal condition exists in the device (IIN1.6).	67
Unable to read point(s) <OBJ.VAR.IDX> on device <device>. Device detected corrupt configuration (IIN2.5).	67
Unable to read point(s) <OBJ.VAR.IDX> on device <device>. Device does not support a point in the range or other parameter error (IIN2.2).	67
Unable to read point(s) <OBJ.VAR.IDX> on device <device>. Device does not support requested operation for objects in the request (IIN2.1).	67
Unable to read point(s) <OBJ.VAR.IDX> on device <device>. Device does not support the function code (IIN2.0).	67
Unable to read point(s) <OBJ.VAR.IDX> on device <device>. Device reports that some output points are in local mode (IIN1.5).	68
Unable to read point(s) <OBJ.VAR.IDX> on device <device>. Device reports that the operation is already executing (IIN2.4).	68
Unable to read point(s) <OBJ.VAR.IDX> on device <device>. Session shutting down or duplicate request.	68
Unable to read point(s) <OBJ.VAR.IDX> on device <device>. Unable to receive response from device <device> within timeout. Either the request or response could not be completed or the response is invalid.	68
Unable to read point(s) <OBJ.VAR.IDX> on device <device>. Unrecognized object returned in response.	69
Unable to read point(s) <OBJ.VAR.IDX – OBJ.VAR.IDX> on device <device>. An abnormal condition exists in the device (IIN1.6).	69

Unable to read point(s) <OBJ.VAR.IDX – OBJ.VAR.IDX> on device <device>. Device detected corrupt configuration (IIN2.5).	69
Unable to read point(s) <OBJ.VAR.IDX – OBJ.VAR.IDX> on device <device>. Device does not support a point in the range or other parameter error (IIN2.2).	70
Unable to read point(s) <OBJ.VAR.IDX – OBJ.VAR.IDX> on device <device>. Device does not support requested operation for objects in the request (IIN2.1).	70
Unable to read point(s) <OBJ.VAR.IDX – OBJ.VAR.IDX> on device <device>. Device does not support the function code (IIN2.0).	70
Unable to read point(s) <OBJ.VAR.IDX – OBJ.VAR.IDX> on device <device>. Device reports that some output points are in local mode (IIN1.5).	70
Unable to read point(s) <OBJ.VAR.IDX – OBJ.VAR.IDX> on device <device>. Device reports that the operation is already executing (IIN2.4).	70
Unable to read point(s) <OBJ.VAR.IDX – OBJ.VAR.IDX> on device <device>. Session shutting down or duplicate request.	71
Unable to read point(s) <OBJ.VAR.IDX – OBJ.VAR.IDX> on device <device>. Unable to receive response from device <device> within timeout. Either the request or response could not be completed or the response is invalid.	71
Unable to read point(s) <OBJ.VAR.IDX – OBJ.VAR.IDX> on device <device>. Unrecognized object returned in response.	71
Unable to read set <set index> of object group <object group> on device <device>. An abnormal condition exists in the device (IIN1.6).	72
Unable to read set <set index> of object group <object group> on device <device>. Device detected corrupt configuration (IIN2.5).	72
Unable to read set <set index> of object group <object group> on device <device>. Device does not support a point in the range or other parameter error (IIN2.2).	72
Unable to read set <set index> of object group <object group> on device <device>. Device does not support requested operation for objects in the request (IIN2.1).	72
Unable to read set <set index> of object group <object group> on device <device>. Device does not support the function code (IIN2.0).	72
Unable to read set <set index> of object group <object group> on device <device>. Device reports that some output points are in local mode (IIN1.5).	73
Unable to read set <set index> of object group <object group> on device <device>. Device reports that the operation is already executing (IIN2.4).	73
Unable to read set <set index> of object group <object group> on device <device>. Session shutting down or duplicate request.	73
Unable to read set <set index> of object group <object group> on device <device>. Unrecognized object returned in response.	73
Unable to read tag address <address> on device <device>. No definition for data set <index>.	74
Unable to read tag address <address> on device <device>. Response missing data.	74
Write Errors	75
Unable to write to address <address> on device <device>. Activate Configuration-Related Status Code <status code> - <description>.	76
Unable to write to address <address> on device <device>. An abnormal condition exists in the device (IIN1.6).	76
Unable to write to address <address> on device <device>. Channel Response Timeout must be between <min. channel response timeout> and <max. channel response timeout>.	76
Unable to write to address <address> on device <device>. Control-Related Status Code <status code>.	76
Unable to write to address <address> on device <device>. Device detected corrupt configuration (IIN2.5).	77
Unable to write to address <address> on device <device>. Device does not support a point in the range or other parameter error (IIN2.2).	77

Unable to write to address <address> on device <device>. Device does not support requested operation for objects in the request (IIN2.1).	78
Unable to write to address <address> on device <device>. Device does not support the function code (IIN2.0).	78
Unable to write to address <address> on device <device>. Device reports that some output points are in local mode (IIN1.5).	78
Unable to write to address <address> on device <device>. Device reports that the operation is already executing (IIN2.4).	78
Unable to write to address <address> on device <device>. Device Request Timeout must be between <min. value> and <max. value>.	78
Unable to write to address <address> on device <device>. Element index <variation> is not defined in data set <index>.	79
Unable to write to address <address> on device <device>. Event Poll Interval must be between <min. value> and <max. value>.	79
Unable to write to address <address> on device <device>. File name writes have been disabled.	79
Unable to write to address <address> on device <device>. Integrity Poll Interval must be between <min. value> and <max. value>.	79
Unable to write to address <address> on device <device>. Master address <master address> already in use as slave address on device <device>.	80
Unable to write to address <address> on device <device>. Master address must be between <min. master address> and <max. master address>.	80
Unable to write to address <address> on device <device>. Master and slave address cannot be the same.	80
Unable to write to address <address> on device <device>. No definition for data set <index>.	80
Unable to write to address <address> on device <device>. Select operate response invalid.	80
Unable to write to address <address> on device <device>. Session shutting down or duplicate request.	81
Unable to write to address <address> on device <device>. Slave address <slave address> already in use on device <device>.	81
Unable to write to address <address> on device <device>. Slave address must be between <min. slave address> and <max. slave address>.	81
Unable to write to address <address> on device <device>. Tag <data type> data type is incompatible with the data set element <data type> data type.	81
Unable to write to address <address> on device <device>. Unable to receive response from device <device> within timeout. Either the request or response could not be completed or the response is invalid.	81
Unable to write to address <address> on device <device>. Unrecognized object returned in response.	82
Unable to write to address <address> on device <device>. Unsupported operation type.	82
Unable to write to address <address> on device <device>. Unsupported Trip-Close Code.	82
Unable to write to address <address> on device <device>. Write value specified is invalid or incomplete.	83
File Control Messages	83
File transfer failure on device <device> for file index <index>. Device returned file-related status code <status code> - <description>.	84
File transfer failure on device <device> for file index <index>. File size of <size> kilobytes is greater than maximum file size of <maximum size> kilobytes.	84
File transfer failure on device <device> for file index <index>. File transfer aborted by user.	84
File transfer failure on device <device> for file index <index>. File transfer aborted due to communications issue.	85
File transfer failure on device <device> for file index <index>. Local file <file name> is empty.	85

File transfer failure on device <device> for file index <index>. Local file open failure. <local file open failure>. 85

File transfer failure on device <device> for file index <index>. Session shutting down or duplicate request. 86

Invalid local file for file Index 70.<file index>, general error. 86

Invalid local file for File Index 70.<file index>, verify the specified path is write-enabled. 86

Invalid local file path for File Index 70.<file index>. 86

Invalid local file syntax for File Index 70.<file index>. 86

Device Profile **88**

 Device Identification 88

 Link Layer 90

 Application Layer 90

 Masters Only 91

 Security Parameters 91

 Implementation Tables 93

Index **100**

DNP3 Master Serial Driver Help

Help version 1.177

CONTENTS

[Overview](#)

What is the DNP3 Master Serial Driver?

[Channel Setup](#)

How do I configure a channel for use with this driver?

[Device Setup](#)

How do I configure a device for use with this driver?

[Data Types Description](#)

What data types does this driver support?

[Address Descriptions](#)

How do I address a data location?

[Error Descriptions](#)

What error messages are produced by the DNP3 Master Serial Driver?

[Device Profile](#)

Where can I find information on the device profile?

Overview

The DNP3 Master Serial Driver provides a reliable way to connect DNP slave serial devices to OPC client applications, including HMI, SCADA, Historian, MES, ERP, and countless custom applications.

Channel Setup

In the DNP3 protocol, a channel describes a communications path between two endpoints. DNP3 sessions describe specific communications between a DNP master node (server channel) and a DNP slave node (server device). For each channel (master node), DNP sessions are represented as server devices (slave nodes). The server channel describes the communications conduit over which the sessions communicate. The other endpoint of the DNP channel may have one or more slave nodes available.

Communication Serialization

The DNP3 Master Serial Driver supports Communication Serialization, which specifies whether data transmissions should be limited to one channel at a time. For more information, refer to "Channel Properties - Advanced" in the server help file.

Timing

The Response Timeout specifies how long the device waits for a response to a request before timing out. The valid range is 100 to 3600000 milliseconds. The default setting is 10000 milliseconds.

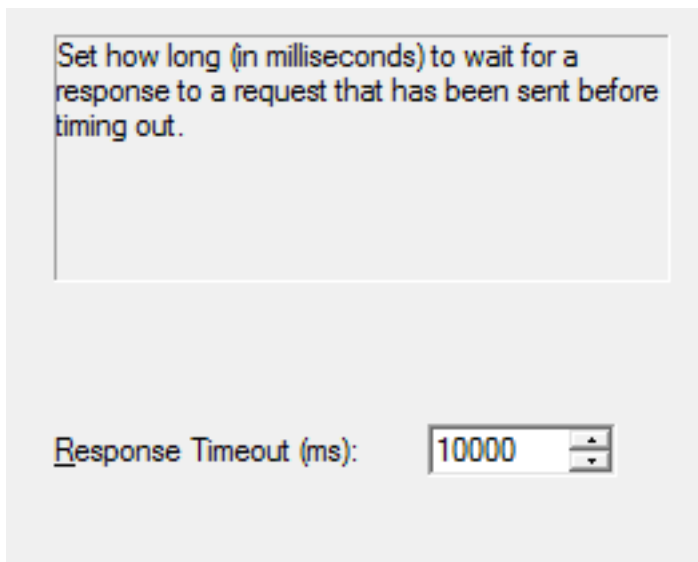

Note: For more information on performance, refer to [Timing and Other Considerations](#).

Device Setup

Communication Protocol

Distributed Network Protocol 3.0 (DNP3).

Supported Devices

Any DNP3 slave device.

Maximum Channels and Devices

The maximum number of channels supported by this driver is 1024. The maximum number of devices supported per channel is 1024.

Note: When using Ethernet Encapsulation, this driver uses one socket per channel.

Flow Control and RS232/485 Converters

When using an RS232/RS485 converter, the type of flow control that is required depends on the needs of the converter. Some converters do not require any flow control whereas others require RTS flow. Consult the converter's documentation to determine its flow requirements. An RS485 converter that provides automatic flow control is recommended.

Note: When using the manufacturer's supplied communications cable, it is sometimes necessary to choose a flow control setting of **RTS** or **RTS Always** in the Communications tab in channel properties.

Device ID

The Device ID property is not available to this driver.

Cable Diagram

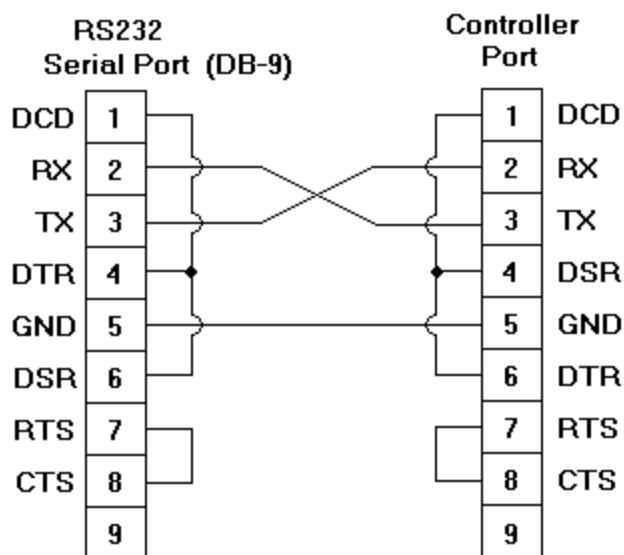

Communications

The Communication Settings section is used to specify the DNP master and slave's 16-bit addresses, request timeout, and the keep alive interval.

Communications	
<input type="checkbox"/> Class Polling <input type="checkbox"/> Unsolicited <input type="checkbox"/> Event Playback	
+ Communication Settings	
- Time Base Options	
UTC	No
Slave Time Zone	(UTC) Coordinated Universal T...
Slave respects DST	Yes
+ Time Synchronization	
Time Base Options The current DNP3 Specification specifies using Coordinated Universal Time (UTC).	

Descriptions of the parameters are as follows:

- **UTC:** This parameter specifies the time base of the DNP slave to be used during time synchronization and event time of occurrences. When Yes is selected, Universal Coordinated Time is used. The default setting is Yes.
Caution: Because the majority of DNP slaves follow the DNP3 Specification and use UTC as their time base, it is not recommended that users change this setting unless it is known that the device does not follow the DNP3 Specification.
- **Slave Time Zone:** This parameter specifies the time zone to be used to set the time in the DNP3 slave. This option is only available when the UTC parameter is set to No. The default setting is (UTC) Coordinated Universal Time, which is set according to the DNP3 specification.
- **Slave respects DST:** This parameter specifies whether the time that is set in the DNP3 slave respects Daylight Saving Time. When No is selected, Daylight Saving Time is ignored. This option is only available when the UTC parameter is set to No. The default setting is No because UTC does not use Daylight Saving Time.

Time Synchronization

The Time Synchronization section is used to specify the device's time synchronization style and delays. Until time synchronization has occurred, it is possible for the reported DNP slave's time information to be inaccurate.

The Event Poll intervals specify how often each Event Class will be polled for data changes.

Class 1 Poll Interval 5 Seconds

Class 2 Poll Interval 5 Seconds

Class 3 Poll Interval 5 Seconds

Integrity Polling

The Integrity Polling dialog is used to specify the frequency with which classes 0, 1, 2, and 3 request data.

The Integrity Poll interval specifies how often Class 0,1,2,3 data will be requested. Integrity polls can also be done when the master restarts, the slave comes online, and/or the slave indicates it has an event buffer overflow.

Integrity Poll Interval (sec) 3600

Issue Integrity Poll on:

- Restart
- Slave Online
- Buffer Overflow

Descriptions of the parameters are as follows:

- **Integrity Poll Interval (sec):** This parameter specifies the frequency with which a complete data retrieval is requested from the DNP slave device. To turn off integrity polling, enter zero (0). The valid range is 0 to 2,592,000 seconds (30 days). The default setting is 3600 seconds.
- **Issue Integrity Poll on:** This parameter specifies when integrity polls occur. Options include Restart, Slave Online, and Buffer Overflow. The default setting is Restart.

Unsolicited Messaging

The Unsolicited Messaging dialog is used to specify whether the DNP slave sends class 1, 2, and 3 unsolicited data updates.

A DNP Slave can be configured to send data updates without solicitation. 'Automatic' takes no action (Slave's discretion). 'Enable' permits unsolicited messages. 'Disable' turns off this feature. Unsolicited messages during startup can be disabled.

Unsolicited Mode Class 1:

Unsolicited Mode Class 2:

Unsolicited Mode Class 3:

Disable unsolicited messaging during startup

Descriptions of the parameters are as follows:

- **Unsolicited Mode Class 1, 2, and 3:** These parameters specify whether unsolicited messaging is allowed. Options include **Automatic**, **Enable**, and **Disable**. Automatic takes no action and is at the slave's discretion. Enable permits the reporting of data updates for the selected classes. Disable turns off unsolicited messaging. The default setting is Automatic.
- **Disable unsolicited messaging during startup:** When checked, this option disables unsolicited messaging during start. This option is only available when one or more classes have Enable selected and no class has been set to Automatic. This setting applies to all Event classes. The default setting is unchecked.

Event Playback

The Event Playback dialog specifies when to retain a set number of updates and deliver them to clients. DNP slave devices may be configured to retain event reports until contacted by a DNP master. The slave typically delivers these event reports in bulk when responding to an integrity poll, event poll, or via unsolicited messages. The DNP driver retains only the most recent update for a given I/O point and discards most or all of the historical stream by default.

Important: Event Playback continues if the device goes into an error state. If the device is still in an error state when playback for the tag completes, the tag quality is bad.

Note: Playback stops if auto-demotion is enabled and the device is demoted.

Enabling event buffering allows event reports from the device to be buffered and then played back so the clients can collect them all.

Enable Event Buffer

Max Events Per Point:

Playback Rate (msecs)

Descriptions of the parameters are as follows:

- **Enable Event Buffer:** When checked, this option allows event reports from the remote DNP device to be buffered and played back for OPC client collection. The default setting is unchecked.

Note: The client may display intermittent buffered values if the slave sends buffered data while Event Playback is turned off.

- **Max. Events Per Point:** This parameter specifies the maximum events to be collected per point. The valid range is 1 to 10000. The default setting is 100.

Note: More than the specified Max. Events Per Point can be played back if the DNP3 Master Serial Driver is in the middle of processing buffered data from the slave and more events arrive (or if Max. Events Per Point is exceeded during the playback).

- **Playback Rate (ms):** This parameter specifies the rate at which event reports are played back. The valid range is 50 to 10000. The default setting is 2000 milliseconds.

Effects of Playback on Clients

1. To assure retrieval of all buffered events, the client must have an update rate that is at least twice as fast as the Playback Rate. If the client's update rate is slower, it effectively overrides the Playback Rate.
2. Event Playback introduces latency to the tags for those affected objects. After the initial burst of events is played out of the buffer, incoming updates are only reported at the Playback Rate. New updates may have a time period of 2000 milliseconds between arriving and reporting to clients (at the default settings).

Note: Buffering should only be used when preservation of the event stream is more important than timely delivery of point updates. If a tag's event buffer fills up, new reports displace the oldest reports in the queue.

Note: Enabling the OPC DA setting **Return initial updates for items in a single callback** may result in loss of buffered data when using drivers that support Event Playback for unsolicited device protocols. The compliance setting should be disabled if loss of buffered data is a concern. See the OPC Compliance Options section in the server help.

Tag Import

The Tag Import dialog is used to specify options for importing tags from the DNP device.

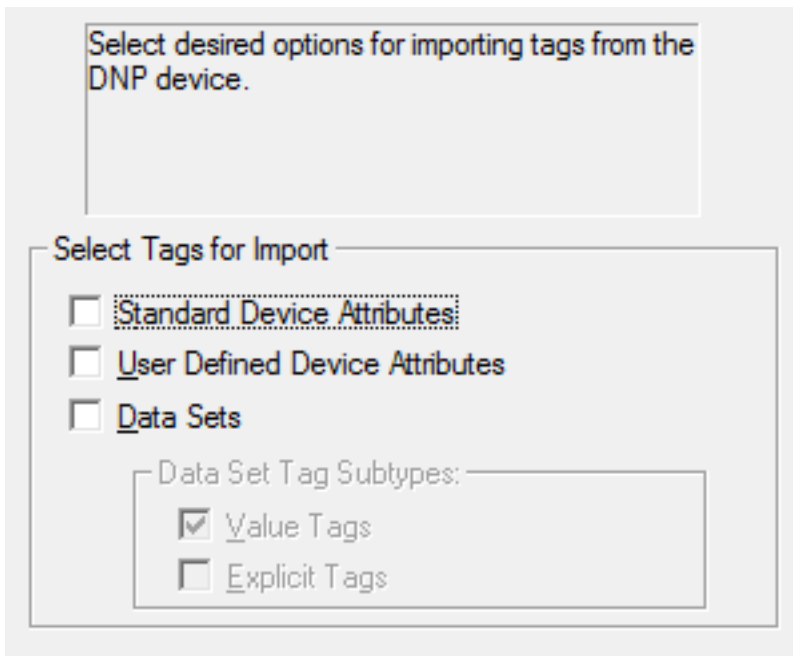

Select desired options for importing tags from the DNP device.

Select Tags for Import

- Standard Device Attributes
- User Defined Device Attributes
- Data Sets
 - Data Set Tag Subtypes:
 - Value Tags
 - Explicit Tags

Descriptions of the parameters are as follows:

- **Standard Device Attributes:** When checked, the driver creates tags for standardized Object Group 0 Device Attributes defined by DNP3 at set index 0. The default setting is unchecked.
- **User Defined Device Attributes:** When checked, the driver creates tags for Object Group 0 Device Attributes indexes 1 and above. The default setting is unchecked.
- **Data Sets:** When checked, the driver creates tags for Object Group 87 - Data Sets. The default setting is unchecked.
Note: The DNP3 Master Serial Driver does not create tags for data sets with more than 32 elements.
- **Data Set Subtypes:** This parameter specifies the sub-type of the data set tags. It is only available when data sets are selected for import. The default setting is Value Tags. For more information on sub-types, refer to [Address Descriptions](#).

Important: The driver creates all tag groups through communication with the device after it determines that tags are available in the target device. For accurate tag import, the communication settings must be correct.

Note: When the Tag Import settings are accessed through the device properties, an **Import Tags** button is available. When clicked, this button imports the tag types specified in Select Tags for Import. If the Enable Authentication device property is checked, authentication statistics tags are also generated. When a tag import is in progress, the properties on this page are disabled. For more information, refer to [Authentication](#).

The screenshot shows a dialog box with two tabs: "Tag Import" and "Authentication". The "Tag Import" tab is active. Inside the dialog, there is a section titled "Select Tags for Import" which contains three unchecked checkboxes: "Standard Device Attributes", "User Defined Device Attributes", and "Data Sets". Below this section is a "Data Set Tag Subtypes" section with two checkboxes: "Value Tags" (checked) and "Explicit Tags" (unchecked). At the bottom right of the dialog is an "Import Tags" button.

Authentication

The Authentication dialog is used to configure the device's authentication settings.

Enabling authentication allows the master to unambiguously determine that it is communicating with the correct outstation.

Enable Authentication

Enable Aggressive Mode Support

Session Key

Change Interval (sec):

Change Count:

Reply Timeout (msec):

Max Error Count:

Descriptions of the parameters are as follows:

- Enable Authentication:** When checked, this parameter enables authentication. If the device requires authentication, the master must configure it as well. The default setting is unchecked.

Note: A tag import is performed when this property changes. This ensures that the authentication object internal Statistics tags are automatically generated when authentication is enabled. These tags are pre-defined, and may be imported without communication with the device. When authentication is disabled, a tag import is performed to remove the authentication object internal Statistics tags. When a tag import is in progress, the properties on this page are disabled. For more information, refer to [Tag Import](#).
- Enable Aggressive Mode Support:** When checked, this parameter reduces traffic by not requiring a critical request "challenge and reply" after at least one "challenge and reply" was successful during the session key change interval. The default setting is checked.
- Session Key Change Interval (sec):** This parameter specifies the session key change timeout to be used by the master to determine when to change session keys. When a value of 0 is entered, Session Key Change Count is used instead. The valid range is 0 to 7200 seconds. The default setting is 900 seconds.
- Session Key Change Count:** This parameter specifies the number of transmitted authentication messages at which the master changes session keys. The messages may have been transmitted in either direction. The valid range is 0 to 65535. The default setting is 1000.
- Reply Timeout (ms):** This parameter specifies how long the device waits for an authentication reply. The valid range is 0 to 300000 milliseconds. The default setting is 2000 milliseconds.
- Max. Error Count:** This parameter specifies the number of error messages sent before error message transmission is disabled. It is also used to limit the number of authentication attempts when there is no reply from the slave. With proper timeout settings, the maximum number of authentication retries per response timeout is Max. Error Count + 2. The valid range is 0 to 10. The default setting is 2.

Note: The DNP3 Master Serial Driver automatically matches the HMAC algorithm as configured in the slave.

Update Key Authentication

When "Enable Authentication" is checked, the New Device Wizard presents the following additional dialog. When it is not checked, this dialog is not displayed.

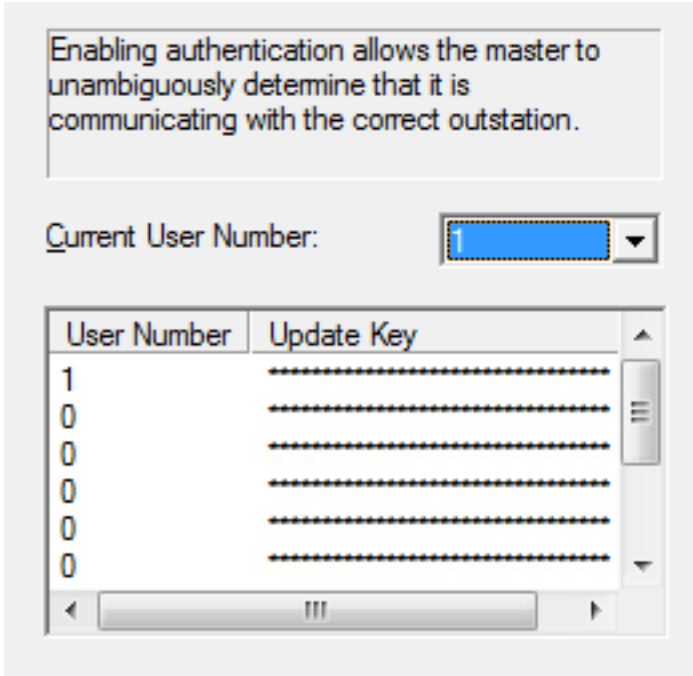

Descriptions of the parameters are as follows:

- **Current User Number:** This parameter specifies the user number to be used to retrieve the Update Key during authentication. The valid range includes only those values in the User Number/Update Key table. The default setting is 1.
- **User Number/Update Key:** This parameter displays an array of 10 users, each with their own 16 hexadecimal byte Update Key. The same User Number/Update Key combination must be configured in the device. The valid range for User Number is 0 to 65535. The default setting for the first row of User Numbers is 1. All others are 0.

To edit a specific row's User Number and Update Key, double-click on it.

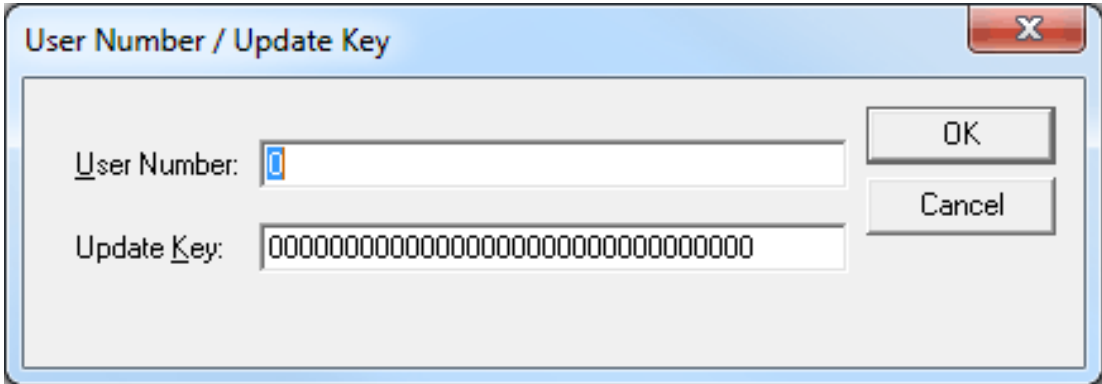

Descriptions of the parameters are as follows:

- **User Number:** This parameter modifies the current User Number.
- **Update Key:** This parameter modifies the existing Update Key. Update Keys can be entered either as 32 characters (such as "493B56AF89120C0429767DB301C63CA8") or as 16 sets of 2 characters that are separated by spaces (such as "49 3B 56 AF 89 12 0C 04 29 76 7D B3 01 C6 3C A8").

File Control

The File Control feature set is intended to be used as a mechanism for transferring log and configuration files between DNP masters and slaves. The DNP3 Master Serial Driver supports the transfer of files to and from a DNP

slave. In the File Control tab of device properties, users can change a setting by clicking in the second column of the parameter. In most cases, this invokes a drop-down menu that displays the available options. For the path properties, this invokes a browse button instead.

Configure the settings for up to 10 files.	
Informational logging	No
File name writes	No
Activate Config Objects	
[-] File Index 70.0	
[-] Local File	.. Overwrite
File Name	
Path	
Open Mode	Overwrite
[-] Remote File	

Descriptions of the parameters are as follows:

- **Informational logging:** When Yes is selected, this parameter logs informational messages to the Event Log during file transfers. When No is selected, informational logging is turned off. In both cases, error messages are always logged to the Event Log. The default setting is No.
- **File name writes:** When Yes is selected, the file name tags are created with read/write access. When No is selected, the file name tags are created with read-only access. The default setting is No.
Note: When the applied setting changes from No to Yes, a message warns the user that writes to the file name tags change the device properties.
- **Activate Config Objects:** This parameter specifies a comma-delimited string that contains a list of the objects to be used in the Activate Configuration Request. All 70.index objects listed in the string must have the remote file name and path defined in the File Index section for that index. All 110.index objects listed must have a tag defined for that data point. For example, the format of this list would be 70.0, 70.1, 110.5. The maximum number of characters allowed for this string is 256.
- **File Index 70.0:** The following local and remote path and file settings, file authentication, and maximum size are for the file index 0.
 - **Local File:** This is the definition of the DNP master local file.
 - **File Name:** This parameter specifies the name of the file located on the master. It can include the entire path, part of the path, or only the file name. If a local path is defined, the local file identifier is defined by either `<local path>\<local file name>` or `<local path>/<local file name>`. The file name property is exposed to the client in a tag. If the **File name writes** property is set to Yes, the client can change the file name as needed by writing to the tag. The maximum number of characters for the file identifier is 256.
 - **Path:** This parameter specifies the local path of the file. When users click in the right column of this property, a browse button is invoked. If the **Local File Name** property contains the entire file identifier, the path property should remain empty. For security, the path property is not exposed to the client in a tag. A non-empty path precedes a backslash (or forward slash) and the local file name to identify the local file. The maximum number of characters for the file identifier is 256.

Note: The local file path and name must form a valid UNC path (which cannot contain the characters `|?*"':<>`). For security purposes, the parent directory (denoted by `'..'`) is not permitted. Furthermore, the current user must have read/write privileges to the local file identifier.
 - **Open Mode:** When **Overwrite** is selected, the local file is overwritten during file transfers. When **Append** is selected, the incoming file data is appended to an existing file. The default setting is Overwrite.
 - **Remote File:** This is the definition of the DNP slave remote file. The remote file identifier is restricted in length to 256 characters. Because the server cannot verify that the file name and

path are valid, users must make sure to specify the path correctly to avoid unintended file transfers. For example, users that set the remote file identifier to a folder/directory on the DNP slave may find that the transfer completes successfully, but that the file cannot be used by the DNP Master.

- **File Name:** This parameter specifies the name of the file located on the slave. This entry can include the entire path, part of the path, or only the file name. If a remote path is defined, then the remote file identifier is defined by either *<remote path>\<remote file name>* or *<remote path>/<remote file name>*. The file name property is exposed to the client in a tag. If the **File name writes** property is set to Yes, then the client can change the file name as needed by writing to the tag. The maximum number of characters for the file identifier is 256.
- **Path:** This parameter specifies the path of the file located on the slave. If the **Remote File Name** property contains the entire file identifier, the path property should remain empty. For security, the path property is not exposed to the client in a tag. A non-empty path precedes a backslash (or forward slash) and the remote file name to identify the remote file. The maximum number of characters for the file identifier is 256.
- **Authentication:** This determines the file authentication. The username and password should be as configured in the device.
 - **User Name:** This parameter specifies the username required by the device to authenticate the file. The maximum number of characters is 32.
 - **Password:** This parameter specifies the password required by the device to authenticate the file. The encrypted password is case-sensitive and is not displayed. The maximum number of characters is 32.
 - **Retype Password:** This parameter verifies the password entered in the parameter above. The encrypted verification password is case-sensitive and is not displayed. The maximum number of characters is 32.
- **Max. file size:** This parameter specifies the maximum file size in kilobytes that are allowed in file transfers. The valid range is 100 to 65535 kilobytes. The default setting is 1000 kilobytes.
- **File Index 70.1 through File Index 70.9:** Up to ten different files can be configured. The properties are persisted to the project.

Note: When property changes are made and applied, a tag import is performed. At that time, a tag group titled "File Control" is created automatically. Four tags for each of the 0-9 file indexes that have non-empty file names or path names are created. The format of the tags is *70.<index>.Upload*, *70.<index>.Download*, *70.<index>.LocalFileName*, and *70.<index>.RemoteFileName*. These tags are pre-defined and may be imported without communication with the device. When a tag import is in progress, the properties on this page are disabled. For more information, refer to [Tag Import](#).

Advanced

The Advanced dialog is used to specify the operate mode, whether to perform a feedback poll after a write, how to display the DNP .Timestamp, whether to exchange data sets on restart, and whether to log informational messages to the Event Log when the device sets the Device Restart or Need Time IIN bits.

Note: In the Advanced tab of device properties, users can change a setting by clicking in the second column of the parameter. In most cases, this invokes a drop-down menu that displays the available options.

Configure advanced settings.	
Operate Mode	Direct Operate
Feedback Poll after operate	Yes
Timestamp to local time	No
Ignore Remote Force flag	No
Ignore Local Force flag	No
Exchange Data Sets	Yes
Device Restart IIN Logging	No
Need Time IIN Logging	No

Descriptions of the parameters are as follows:

- Operate Mode:** This parameter determines whether the writable I/O points (Object Group 10 - Binary Outputs and Object Group 40 - Analog Outputs) use the Direct-Operate or Select-then-Operate sequence. The default selection is Direct Operate.
Note: Individual tag write behavior can override this setting by writing a Boolean True to the output's corresponding .DO or .SO sub-type tags. For more information, refer to [DNP DO and SO sub-types](#).
- Feedback Poll after operate:** When Yes is selected, this parameter enables a feedback poll to occur after an operate. The default setting is Yes.
- Timestamp to local time:** When Yes is selected, this parameter converts the UTC timestamp to local time. It is displayed in .Timestamp tags. The default setting is No.
- Ignore Remote Force flag:** If the DNP Remote Force flag is set and this parameter is set to No, the quality of the corresponding .Value and .Explicit tags is bad. If the DNP Remote Force flag is set at the slave end and this parameter is set to Yes, the quality of the corresponding .Value and .Explicit tags remains good. The default setting is No.
- Ignore Local Force flag:** If the DNP Local Force flag is set and this parameter is set to No, the quality of the corresponding .Value and .Explicit tags is bad. If the DNP Local Force flag is set at the slave end and this parameter is set to Yes, the quality of the corresponding .Value and .Explicit tags remains good. The default setting is No.
- Exchange Data Sets:** When Yes is selected, this parameter ensures that the data set prototypes and descriptors are exchanged with the slave whenever the master or slave restarts. When No is selected, the initial exchange of data sets does not take place. If a data set tag needs to be updated, the data set prototype and descriptors must be exchanged before requesting the update. If the master restarts and does not exchange data sets, any data set events that occurred before the master restarted are lost: the master has no knowledge of the data sets. The default setting is No.
- Device Restart IIN Logging:** When Yes is selected, this parameter logs informational messages to the Event Log when a response from the slave has the Device Restart IIN 1.7 bit set. When No is selected, informational logging is turned off. The default setting is No.
- Need Time IIN Logging:** When Yes is selected, this parameter logs informational messages to the Event Log when a response from the slave has the Need Time IIN 1.4 bit set. When No is selected, informational logging is turned off. The default setting is No.

Note: For more information on DNP flag bytes, refer to "DNP Object Flag Definitions" located in Object Group 1, 3, 10, 20, 21, 30, and 40.

Timing and Other Considerations

Suggested Time Settings

Since the DNP3 protocol keeps communications at a minimum, the following suggested settings help the OPC server and driver operate efficiently.

- Only one transaction can be handled on the communications channel at a time. In situations where multiple devices share a single communications channel, the driver must move from one device to the next as quickly as possible to gather information at an effective rate. As more devices are added (or more

information is requested from a device), the overall update rate begins to suffer.

Note: An unresponsive device blocks the other devices on that channel from receiving service while the Channel Response Timeout elapses. The explicit requests to the devices slows down and the event poll intervals is affected once one or more devices fail to respond.

2. The entire send and receive transaction for a device must complete within the device Request Timeout. If the send is successful, the response must be received within the Channel Response Timeout. The device Request Timeout should be greater than or equal to the Channel Response Timeout.
3. Timeouts should be set to accommodate the responsiveness of a particular slave device: they should not be set too low. For example, if the device Request Timeout and/or Channel Response Timeout were set to zero, the driver would be perpetually timed out and all effective communication would cease. Under these circumstances, users would likely receive Event Log error messages such as "Device <device name> is not responding". To determine the best settings for the Channel Response Timeout and the device Request Timeout, consider the following example:

There is one communications channel for 10 devices, and 9 of them are offline. Each device waits the duration of the Channel Response Timeout (default setting 10 seconds), which blocks the other devices. To keep the tenth device from failing due to the device Request Timeout (default setting 30 seconds), the device Request Timeout must be longer than it takes all of the offline devices to timeout one at a time. In this situation, a device Request Timeout of 100 seconds should allow the tenth device to successfully complete its send and receive transaction after the nine devices timed out.

4. If the channel response timeout is longer than a device's poll interval, a delay may occur in event polling. For example, a device that shares a channel with other devices is not responding. If any device on that channel has a poll interval set at a shorter rate than the channel response timeout, the poll interval rate for that device is not met. Event polling occurs as soon as the timeout has elapsed and the device is serviced. Once the device begins communicating again, the event poll interval returns to its defined rate.
5. Object Group 50 is the slave's clock. Since it cannot be received in event polls or through unsolicited messages, the DNP Master Driver must explicitly request a read. Furthermore, because it is a time datum, the driver requests a read every time the tag is pulled for an update. On a default instantiation, that is every 200 ms. To avoid congesting the communications link, create a separate OPC group for the object 50 time tag and then set that group's update rate to 1000 ms or slower. For more information on all objects, refer to [Object Definitions](#).

Note: There are a variety of communication serialization tags that can be used to debug timing issues involving a serialization network. For more information, refer to "Communication Serialization Tags" in the server help documentation.

Effects of DNP Devices Going Offline

When a device goes offline, it may disrupt the DNP communications for all devices using the same channel. This is because DNP is a synchronous protocol; meaning, it requires an acknowledgment, timeout, or confirmed failure for the current command before the next command in the queue may be transmitted. The OPC driver often queues multiple commands within a typical DNP timeout period. The DNP stack must dispose of these commands in the order they are received. Outstanding commands for still-responsive slave devices can be blocked until the command queue empties. For more examples of offline scenarios, refer to "Suggested Time Settings" above.

Note: Devices that have gone offline cause a delay in the shutdown of the OPC server while the server waits for timeouts to expire.

Modem Setup

This driver supports modem functionality. For more information, please refer to the topic "Modem Support" in the OPC Server Help documentation.

Data Types Description

Data Type	Description
Boolean	Single bit
Word	Unsigned 16-bit value bit 0 is the low bit bit 15 is the high bit
Short	Signed 16-bit value bit 0 is the low bit bit 14 is the high bit bit 15 is the sign bit
DWord	Unsigned 32-bit value bit 0 is the low bit bit 31 is the high bit
Long	Signed 32-bit value bit 0 is the low bit bit 30 is the high bit bit 31 is the sign bit
Float	32-bit floating-point value
Double	64-bit floating-point value
String	Null terminated ASCII string

Address Descriptions

Tag Addressing

Tag addressing is of the form *OBJ.VAR.IDX.SUB (ObjectGroup.Variation.Index.Sub-Type)*, where:

- **OBJ:** The data object group.
- **VAR:** The variation requested for the tag equates to data type. Strings do not have a variation component. **Note:** The variation is only applicable to .Value and .Explicit sub-types. For .Value tags, no request is sent to the slave. All variations defined for .Value tags in the master display the value in the slave's default event variation. For .Explicit tags, the variation is used in the request to the slave. If the request is for variation 0, the slave returns the value in its default static variation. All other variations for .Explicit tags are specifically requested from the slave.
- **IDX:** The specific data object in a given group. For example, IDX 4 is the 5th binary input. Indexes start with 0 for each object group with multiple points. Some objects, such as Objects 50 and 60, do not have an index component.
- **SUB:** The specific attribute of the point.

See Also: [Other Object Groups](#)

Sub-Types

Values reported to the server from the slave device are in the slave device's default variation (which may differ from the server default variation) and are obtained through report by exception. Certain object group variations in the DNP3 protocol return multiple data items. For example, Object Group 20.1 asks for an analog input point's 32-bit Value as well as a Flag byte. Many event object groups variations also return the time of occurrence: because the OPC interface does not handle complex data types; the Value, Flags, and Timestamp data are not available in a single tag. The OPC server must retrieve the various parts of the combined report in separate tags.

- For the .SUB Value attribute, the data type is designated by the variation (.VAR). If the variation is .0, the .SUB Value attribute has the same data type as the default variation.
- For the .SUB Flags attributes contained within the Flags attribute, the data type is always Boolean. They are unaffected by the variation.
- For the .SUB Flags attribute, the data type is always Byte. It is unaffected by the variation.
- The .SUB Timestamp attribute is always Date. It is unaffected by the variation.

Sub-Type	Description
Value	The current value of the point. The data type returned from the slave depends on the default event variation and the default static variation configured in the slave for the point. The data type exposed to the client depends on the variation part of the tag address.
Explicit	<p>The current value of the point. The data type varies as determined by the selected variation. Reading a tag with the Explicit sub-type causes the driver to initiate a DNP read transaction.</p> <p>DNP is usually used in a report-by-exception model, where the DNP slave device responds to an Event Poll with the point data that has changed since the last report. Some DNP slave devices may have I/O points that are not configured to answer to Event or Integrity polls. These points require special handling via the .Explicit sub-type. The .Explicit sub-type triggers a DNP read transaction for every tag update, which may cause traffic on the DNP bus. Tags using the .Explicit sub-type must use a suitable update rate. Rates of 1000 ms or longer are recommended, as is limiting the use of .Explicit tags to only where required. It is the user's responsibility to configure .Explicit tags appropriately.</p> <p>Note: To reduce traffic, Explicit reads of the same object group and variation are blocked together to be read 64 at a time. If any tag in the block fails, the whole block fails.</p>
Timestamp	<p>The date and time of the last update received from slave (if an event has occurred and the time of occurrence was returned).</p> <p>A successful write to a .Value or .Explicit tag causes its corresponding .Timestamp tag quality to be bad. The timestamp of the .Timestamp tag is the timestamp of the update from the write. The next time a DNP timestamp is received, the quality of the .Timestamp tag changes to good and its timestamp displays the DNP timestamp.</p>

Sub-Type	Description
	Note: The timestamp of the .Value item is only updated if its value has changed since the last update. To find the current DNP timestamp value for the point, use the DNP .Timestamp tag.
Online	Boolean: True if the slave is online.
Restart	Boolean: True if the slave has been restarted.
Lost	Boolean: True if communications with this point were lost.
RemoteForce	Boolean: True if the point value is forced to its current state at a device other than the end device.
LocalForce	Boolean: True if the point value is forced to its current state at the end device. Note: Local force is not yet implemented.
Chatter	Boolean: True if the slave's chatter filter is activated and applying correction.
Reference Check	Boolean: True if the reference signal used to digitize the analog input is not stable and the resulting digitized value may not be correct.
Over-range	Boolean: True if the digitized signal or calculation has exceeded its range. The actual value field can be ignored as its value is not defined.
DO*	Boolean: True if a writable point is set to Direct Operate mode. Writing to a tag of this sub-type overrides the global operate Mode setting. For more information, refer to Operate Mode .
SO*	Boolean: True if a writable point is set to Select-then-Operate Mode. Writing to a tag of this sub-type overrides the global operate Mode setting. For more information, refer to Operate Mode .
Flags	The full set of transaction flags (0 through 7) for the specified DNP point.
Operate	This limited functionality is only retained to support older projects. New projects should use the enhanced operate commands shown below.** The user specifies a crafted value to write. The .Operate sub-type is implemented as a DWord, but currently only the lowest 8 bits are significant. Bits 0-3 form a command number. Allowable values are currently 0-4. Values outside this range result in a failed write. The commands are as follows: 0 - No operation 1 - Pulse on 2 - Pulse off 3 - Latch on (same as writing a 1 to 10.x.x.Value) 4 - Latch off (same as writing a 0 to 10.x.x.Value) Bit 4 is the Queue command modifier. Bit 5 is the Clear command modifier. Bits 6 & 7 form a Trip-Close command pair. Allowable values are currently 0-2. Values outside this range result in a failed write. Bit 6 is the Paired Close command modifier. Bit 7 is the Paired Trip command modifier. The allowable commands are as follows: 0 - Nul 1 - Close 2 - Trip
Enhanced Operate Controls	These expanded operate sub-types allow a user to completely control commands sent to a Control Relay Output Block.**
Operate.OpType	This Byte contains the specific operation type to perform. The commands are as follows: 0 - No operation 1 - Pulse on 2 - Pulse off 3 - Latch on (same as writing a 1 to 10.x.x.Value) 4 - Latch off (same as writing a 0 to 10.x.x.Value)

Sub-Type	Description
Operate.TripCloseCode	This Byte contains the Trip-Close code to apply to the operation. The commands are as follows: 0 - No operation 1 - Close 2 - Trip
Operate.Clear	This Boolean adds the 'Clear' attribute to the command.
Operate.OnTime	This DWord specifies the on-time in milliseconds for the command.
Operate.OffTime	This DWord specifies the off-time in milliseconds for the command.
Operate.FeedbackDelay	This DWord specifies the time in milliseconds before a feedback poll is performed after the command completes.
Operate.Set	After all of the parameters above have been written, writing true to this Boolean initiates the command.

*Direct Operate (DO) and Select-then-Operate (SO) sub-types apply only to Object Groups 10 and 40. DO and SO are not allowed for other object groups.

**See Also: [Object 10 - Binary Outputs](#).

Object Group 0 - Device Attributes

These tags are only read explicitly once after start up. If the device does not support Object Group 0 (or the specific variation), the tag quality is bad; as such, explicit reads of this tag does not resume until the master or slave restarts.

Attributes

The default data type is shown in **bold**.

OBJ.VAR.IDX Attributes*	.SUB Attribute	Data Type	Access
0.{1-253}.{0-65535}	Value	Byte, Char, Double, DWord , Float, Long, Short, String**, Word	Read/Write

*The IDX attribute indicates the particular set of device attributes that are defined in the device. The set of standardized device attributes defined by DNP3 are accessible at set index 0; indexes 1 and above are available for vendor-specific attributes.

**Device attribute strings have a maximum length of 210 characters.

Note: Flags do not apply.

Variations

Variations for Object Group 0 do not equate to a specific data type. A variation is a specific element for a set of device attributes. If the tag is configured by the user, the variation's data type must match the data type that is configured in the slave.

Although the DNP protocol allows requests for Object Group 0, variations 254 and 255, the DNP Master Serial Driver does not allow tags to be created with those variations. The responses to each of those requests may be too large for a tag value.

Number	Description
254	This attribute is used as shorthand to request that a device return all of its attributes in a single response.
255	This special attribute is used to retrieve a list of all the device attribute variation numbers (in addition to their properties) that are supported by the device at a specified index.

Note: Tags with other device attribute variations can both be manually created and automatically generated through the Tag Import settings in device properties. During tag import, the driver issues requests for Group 0 Variation 254 and Group 0 Variation 255 to gather information from the device and to create only those device attribute tags as defined in the responses. For more information, refer to [Tag Import](#).

Examples

Tag Address	Definition	Description
0.211.0.Value	Displays the standard DNP device attribute Number of Analog Outputs.	<p>If a value for this tag has not been received from the device, an explicit request is sent. Once the point has been initialized, the tag receives its updates from the datastore. A second explicit request is only issued if the slave or master restarts.</p> <p>If the response to the initial request indicates that the device does not support the variation 211 of set 0, then no other request is issued and tag quality is bad. The user must configure the tag's data type to match the data type as configured by the slave.</p>
0.250.0.Value	Displays the standard DNP device attribute Manufacturer's product name and model.	<p>If a value for this tag has not been received from the device, an explicit request is sent. Once the point has been initialized, the tag receives updates from the datastore. A second explicit request is only issued if the slave or master restarts.</p> <p>If the response to the initial request indicates that the device does not support variation 250 of set 0, then no other request is issued and the tag quality is bad. The user must configure the tag's data type to match the data type as configured by the slave.</p>
0.211.1.Value	Displays the custom device attribute set 1 variation 211 value.	<p>If a value for this tag has not been received from the device, an explicit request is sent. Once the point has been initialized, the tag receives updates from the datastore. A second explicit request is only issued if the slave or master restarts.</p> <p>If the response to the initial request indicates that the device does not support variation 211 of set 1, then no other request is issued and the tag quality is bad. The user must configure the tag's data type to match the data type as configured by the slave.</p>

Object Group 1 - Binary Inputs

The status for each point in an object group is retained on each transaction; all flags are reported in their sub-type tags. The corresponding event object may also return Time of Occurrence.

Note: Object Group 1 - Binary Input State is reflected in Object Group 2 - Binary Input Change Event. For more information, refer to [Other Object Groups](#).

Attributes

The default data type is shown in **bold**.

OBJ.VAR.IDX Attributes	.SUB Attribute	Data Type	Access
1.{0,1,2}.{0-65535}	Chatter, LocalForce, Lost, Online, RemoteForce, Restart	Boolean	Read Only
1.{0,1,2}.{0-65535}	Flags	Byte	Read Only
1.{0,1,2}.{0-65535}	Timestamp	Date	Read Only
1.0.{0-65535}	Value, Explicit	Boolean	Read Only
1.1.{0-65535}	Value, Explicit	Boolean	Read Only
1.2.{0-65535}	Value, Explicit	Byte	Read Only

Variations

Number	Description
0	Variation determined by slave device
1	Packed format
2	With Flags

DNP Object Flag Definitions

If the device returns an exception bit set, the quality of the .Value or .Explicit tag is bad. The following available bits are exception bits, excluding Online and State. Descriptions are as follows:

- 0: Online
- 1: Restart
- 2: Communications Lost
- 3: Remote Force
- 4: Local Force
- 5: Chatter
- 6: Reserved
- 7: State - Status of input.

Examples

Tag Address	Definition	Description
1.0.0.Value*	Value of point 0 as a Boolean	This tag is updated from the datastore that is populated via responses to integrity and event polls. An explicit request is not sent to the device. Although the slave can return variation 1 or 2 (depending on its Object Group 2 default event variation), this tag displays the state of the binary input point 0 without the flags.
1.0.5.Explicit	Value of point 5 as a Boolean	An explicit request is sent to the device to get the value for this tag. Other object 1 variation 0 Explicit tags are blocked with this tag in one request. Although the slave can return variation 1 or 2 (depending on its default static variation), this tag displays the state of the binary input point 5 without the flags.
1.1.10.Explicit	Value of point 10 as a Boolean	An explicit request is sent to the device to get the value for this tag. Other object 1 variation 1 Explicit tags are blocked with this tag in one request. Although the slave may have returned the response with other points in a packed format, this tag only displays the 0 or 1 based on the state of point 10.
1.1.10.Value*	Value of point 10 as a Boolean	This tag is updated from the datastore that is populated via responses to integrity and event polls. An explicit request is not sent to the device. The variation of 1 in the tag address sets the data type of the tag, but does not define the data type returned by the slave. The slave uses object 2 default event variation.
1.2.10.Explicit	Value of point 10 as a byte	An explicit request is sent to the device to get the value for this tag. Other object 1 variation 2 Explicit tags are blocked with this tag in one request. This tag displays the status of the point as a byte, where bits 0-6 are the flags and bit 7 is the state of the digital input point 10.
1.0.8.Timestamp*	Event Time of Occurrence of point 8 (if an event has occurred and the time of occurrence was returned)	This tag is updated from the datastore that is populated via responses to integrity and event polls. An explicit request is not sent to the device. This tag shows a timestamp of 1999-11-30T00:00:00 or 1899-12-30T00:00:00. It has bad quality until the device sends an event with the time. The Object Group 2 default event variation on the device needs to be 2 or 3 for it to return the event time of occurrence.
1.0.9.Flags*	Latest Flag byte for point 9	This tag is updated from the datastore that is populated via responses to integrity and event polls or an explicit request for binary input point 9. An explicit request is not sent to the device. The value of this tag displays the latest flags' byte received for point 9 (regardless of the variation in the tag address).
1.0.3.Lost*	Latest state of bit 2 of the Flag byte for point 3	This tag is updated from the datastore that is populated via responses to integrity and event polls or an explicit request for binary input point 3. An explicit request is not sent to the device. The value of this tag displays the state of bit 2 from the flags byte received for point 3 (regardless of the variation in the tag address).

*If an event time of occurrence is received with the event, then the tag's OPC timestamp should display the master's local time in which the event occurred within the slave. *For more information, refer to [Communications](#).*

Object Group 3 - Double-Bit Inputs

The status for each point in an object group is retained on each transaction; all flags are reported in their sub-type tags. The corresponding event object may also return Time of Occurrence.

Note: Object Group 3 - Double-Bit Input State is reflected in Object Group 4 - Double-Bit Input Change Event. For more information, refer to [Other Object Groups](#).

Attributes

The default data type is shown in **bold**.

OBJ.VAR.IDX Attributes	.SUB Attribute	Data Type	Access
3.{0,1,2}.{0-65535}	Chatter, LocalForce, Lost, Online, RemoteForce, Restart	Boolean	Read Only
3.{0,1,2}.{0-65535}	Flags	Byte	Read Only
3.{0,1,2}.{0-65535}	Timestamp	Date	Read Only
3.0.{0-65535}	Value, Explicit	Byte	Read Only
3.1.{0-65535}	Value, Explicit	Byte	Read Only
3.2.{0-65535}	Value, Explicit	Byte*	Read Only

*The extra bits are used to provide Flags.

Variations

Number	Description	Available Bits
0	Variation determined by slave device	N/A
1	Packed format	Bits 0 and 1: 0 is Intermediate, 1 is OFF, 2 is ON, 3 is Indeterminate.
2	With Flags	Bits 6 and 7: 0 is Intermediate, 1 is OFF, 2 is ON, 3 is Indeterminate.

DNP Object Flag Definitions

If the device returns an exception bit set, the quality of the .Value or .Explicit tag is bad. The following available bits are exception bits, excluding Online and State. Descriptions are as follows:

- 0: Online
- 1: Restart
- 2: Communications Lost
- 3: Remote Force
- 4: Local Force
- 5: Chatter
- 6: State - Status of input
- 7: State - Status of input

Examples

Tag Address	Definition	Description
3.0.0.Value*	Value of point 0 as a byte	This tag is updated from the datastore that is populated via responses to integrity and event polls. No explicit request is sent to the device. Although the slave can return variation 1 or 2 (depending on its Object Group 4 default event variation), this tag displays the state of the double-bit binary input point 0 without the flags.
3.0.5.Explicit	Value of point 5 as a byte	An explicit request is sent to the device to get the value for this tag. Other Object 3 Variation 0 Explicit tags are blocked with this tag in one request. Although the slave can return variation 1 or 2 (based on its default static variation), this tag displays the state of the double-bit binary input point 5 without the flags.
3.1.10.Explicit	Value of point 10 as a byte	An explicit request is sent to the device to get the value for this tag. Other Object 3 Variation 1 Explicit tags are blocked with this tag in one request. Although the slave returned the response in a packed format, possibly with other points, this tag only shows 0 (intermediate), 1 (Off), 2 (On), or 3 (indeterminate); depending on the state of point 10.

Tag Address	Definition	Description
3.1.10.Value*	Value of point 10 as a byte	This tag is updated from the datastore that is populated via responses to integrity and event polls. No explicit request is sent to the device. The variation of 1 in the tag address sets the data type of the tag, but does not define the data type returned by the slave (which uses its object 4 default event variation).
3.2.10.Explicit	Value of point 10 as a byte	An explicit request is sent to the device to get the value for this tag. Other Object 3 Variation 2 Explicit tags are blocked with this tag in one request. This tag displays the status of the point as a byte where bits 0-5 are the flags and bits 6 & 7 are the state of the digital input point 10.
3.0.8.Timestamp*	Event Time of Occurrence of point 8 (if an event has occurred and the time of occurrence was returned)	This tag is updated from the datastore that is populated via responses to integrity and event polls. No explicit request is sent to the device. This tag shows a timestamp of 1999-11-30T00:00:00 or 1899-12-30T00:00:00. It has bad quality until the device sends an event with the time. The Object Group 4 default event variation on the device needs to be 2 or 3 for it to return the event time of occurrence.
3.0.9.Flags*	Latest Flag byte for point 9	This tag is updated from the datastore that is populated via responses to integrity and event polls or an explicit request for binary input point 9. No explicit request is sent to the device. The value of this tag displays the latest flags' byte received for point 9 regardless of the variation in the tag address.
3.0.3.Lost*	Latest state of the bit 2 of the Flag Byte for point 3	This tag is updated from the datastore that is populated via responses to integrity and event polls or an explicit request for binary input point 3. No explicit request is sent to the device. The value of this tag displays the state of bit 2 from the flags byte received for point 3 regardless of the variation in the tag address.

*If an event time of occurrence is received with the event, then the tag's OPC timestamp should display the master's local time in which the event occurred within the slave. *For more information, refer to [Communications](#).*

Object Group 10 - Binary Outputs

The status for each point in an object group is retained on each transaction; all flags are reported in their sub-type tags. The corresponding event object may also return Time of Occurrence.

Note: Object Group 10 - Binary Output State is reflected in Object Group 11 - Binary Output Change Event, Object Group 12 - Control Relay Output Block, and Object Group 13 - Binary Output Command Event. For more information, refer to [Other Object Groups](#).

See Also: [Object Group 12 - Binary Output Commands](#)

Attributes

The default data type is shown in **bold**.

OBJ.VAR.IDX Attributes	.SUB Attribute	Data Type	Access
10.{0,1,2}.{0-65535}	LocalForce, Lost, Online, RemoteForce, Restart	Boolean	Read Only
10.{0,1,2}.{0-65535}	DO, SO	Boolean	Read/Write
10.{0,1,2}.{0-65535}	Operate.Set, Operate.Clear	Boolean	Read/Write
10.{0,1,2}.{0-65535}	Operate.OpType, Operate. TripCloseCode	Byte	Read/Write
10.{0,1,2}.{0-65535}	Operate.OnTime, Operate. OffTime, Operate. FeedbackDelay	DWord	Read/Write
10.{0,1,2}.{0-65535}	Flags	Byte	Read Only
10.{0,1,2}.{0-65535}	Timestamp	Date	Read Only
10.0.{0-65535}	Value, Explicit	Boolean	Read/Write
10.1.{0-65535}	Value, Explicit	Boolean	Read/Write
10.2.{0-65535}	Value, Explicit	Byte*	Read Only

*The extra bits are used to provide Flags.

Variations

Number	Description
0	Variation determined by slave device
1	Packed format
2	Status with Flags

DNP Object Flag Definitions

If the device returns an exception bit set, the quality of the .Value or .Explicit tag is bad. The following available bits are exception bits, excluding Online and State. Descriptions are as follows:

- 0: Online
- 1: Restart
- 2: Communications Lost
- 3: Remote Force
- 4: Local Force
- 5: Reserved
- 6: Reserved
- 7: State - Status of input.

Binary Output Examples

Tag Address	Definition	Description
10.0.0.Value*	Value of point 0 as a Boolean	This tag is updated from the datastore that is populated via responses to integrity and event polls. No explicit request is sent to the device. Although the slave can return variation 1 or 2 (depending on its Object Group 11 default event variation), this tag displays the state of the binary output point 0 without the flags.
10.0.5.Explicit	Value of point 5 as a Boolean	An explicit request is sent to the device to get the value for this tag. Other object 10 variation 0 Explicit tags are blocked with this tag in one request. Although the slave can return variation 1 or 2 (depending on its default static variation), this tag displays the state of the binary output point 5 without the flags.
10.1.10.Explicit	Value of point 10 as a Boolean	An explicit request is sent to the device to get the value for this tag. Other object 10 variation 1 Explicit tags are blocked with this tag in one request. Although the slave may return the response with other points in a packed format, this tag only shows the 0 or 1 (based on the state of point 10).
10.1.10.Value*	Value of point 10 as a Boolean	This tag is updated from the datastore that is populated via responses to integrity and event polls. No explicit request is sent to the device. The variation of 1 in the tag address sets the data type of the tag. It does not define the data type returned by the slave, which uses its Object Group 11 default event variation.
10.2.10.Explicit	Value of point 10 as a byte	An explicit request is sent to the device to get the value for this tag. Other object 10 variation 2 Explicit tags are blocked with this tag in one request. This tag displays the status of the point as a byte, where bits 0-6 are the flags and bit 7 is the state of the digital output point 10.
10.0.8.Timestamp*	Event Time of Occurrence of point 8 (if an event has occurred and the time of occurrence was returned)	This tag is updated from the datastore that is populated via responses to integrity and event polls. No explicit request is sent to the device. This tag shows a timestamp of 1999-11-30T00:00:00 or 1899-12-30T00:00:00. It has bad quality until the device sends an event with the time. The Object Group 11 default event variation on the device needs to be 2 for it to return the event time of occurrence.
10.0.9.Flags*	Latest Flag byte for point 9	This tag is updated from the datastore that is populated via responses to integrity and event polls or an explicit request for binary output point 9. No explicit request is sent to the device. The value of this tag displays the latest flags' byte received for point 9 (regardless of the variation in the tag address).
10.0.3.Lost*	Latest state of bit 2 of the Flag byte	This tag is updated from the datastore that is populated via

Tag Address	Definition	Description
	for point 3	responses to integrity and event polls or an explicit request for binary output point 3. No explicit request is sent to the device. The value of this tag displays the state of bit 2 from the flags' byte received for point 3 (regardless of the variation in the tag address).
10.0.2.DO*	Boolean value indicating if operations on binary output point 2 should be Direct Operate or Select then Operate	Writing to this tag does not cause an explicit write to the device. It does not change the overall device property for operate Mode: it only changes it for Binary Output point 2. The variation of the tag does not matter. The value of this tag is used when an operation is performed on binary output point 2 either using the operate sub-type commands or a synchronous/asynchronous write to a 10.x.2.Value or 10.x.2.Explicit tag.
10.0.2.SO*	Boolean value indicating if operations on binary output point 2 should be Direct Operate or Select then Operate	Writing to this tag does not cause an explicit write to the device. It also does not change the overall device property for operate Mode: it only changes it for Binary Output point 2. The variation of the tag does not matter. The value of this tag is used when an operation is performed on binary output point 2 either using the operate sub-type commands or a synchronous/asynchronous write to a 10.x.2.Value or 10.x.2.Explicit tag.

*If an event time of occurrence is received with the event, then the tag's OPC timestamp should display the master's local time in which the event occurred within the slave. For more information, refer to [Communications](#).

Object Group 12 - Binary Output Commands

Control Relay Output Block Operate Command Examples

To perform digital control operations (such as electro-mechanical relays) at binary output points using Object Group 12, variation 1, use tags addressed with Object Group 10. An operation on an Object Group 10 tag issues the CROB command using Object Group 12, Variation 1. Depending on the Feedback Poll after Operate device property, another request may be sent after the actual operate request to obtain the latest value of all binary output points. If the operate is successful, but the feedback poll fails; the device reports status code 4. For more information, refer to [Advanced](#).

See Also: [Unable to write to address <address> on device <device>. Control-Related Status Code <status code>](#)

The following example discusses how to issue a Select-then-Operate request for Binary Output point 10 that closes the point one time for 250 milliseconds.

1. To start, click **Device Properties | Advanced**. Then, set the **Operate Mode** to **Select-t Then Operate**.

Note: If the device's operate Mode is Direct Operate, create a tag with the address "10.0.10.SO". Then, write "1" to that tag.

2. Next, create a tag with the address "10.0.10.Operate.Optype". Then, write "1" to that tag. This sets the **Operation Type Field** of the **Control Code** to **Pulse On**.
3. Next, create a tag with the address "10.0.10.Operate.Tripclosecode". Then, write "1" to that tag. This sets the **Trip-Close Code Field** of the **Control Code** to **Close**.
4. Next, create a tag with the address "10.0.10.Operate.Ontime". Then, write "250" to that tag. This sets the duration (in milliseconds) in which the output drive remains active.
5. Next, create a tag with the address "10.0.10.Operate.Set". Then, write "1" to that tag. This triggers the master to send the Object Group 12, variation 1 request performs the digital control operation.

See Also: [Object Group 10 - Binary Outputs](#)

Note: The channel diagnostics should display the three transactions. The master sends a request using function code 0x03 to select the output point. The slave responds by echoing the request if everything is okay. The master sends the operate request using function code 0x04. The slave responds by echoing the request if everything is okay. The master sends the feedback poll and the slave responds with the current static value for all binary outputs.

Tag Address	Definition	Description
10.0.2.Operate.Clear	Value of the CROB control code bit 5	This Boolean tag displays a 0 or 1, depending on the last update from the client. The variation of the tag does not matter. Writing to this tag does not cause an explicit write to the device. It is used in building the CROB control code to be written to the object group 12 point 2 with the Operate.Set tag.
10.0.2.Operate.OpType	Value of the CROB control code bits 0-3	This byte tag displays the operation type; depending on the last update from the client. Operation types are as follows: Nul (0) Pulse_On (1) Pulse_Off (2) Latch_On (3) Latch_Off (4) The variation of the tag does not matter. Writing to this tag does not cause an explicit write to the device. It is used in building the CROB control code to be written to the Object Group 12 point 2 with the Operate.Set tag.
10.0.2.Operate.TripCloseCode	Value of the CROB control code bits 6 & 7	This byte tag displays the Trip-Close Field, depending on the last update from the client. Trip-close fields are as follows: Nul (0) Paired_Close (1) Paired_Trip (2) The variation of the tag does not matter. Writing to this tag does not cause an explicit write to the device. It is used in building the CROB control code to be written to the Object Group 12 point 2 with the Operate.Set tag.
10.0.2.Operate.OnTime	Value in milliseconds that the operation on the binary output point 2 remains active	This DWord tag displays the on time last updated from the client. The variation of the tag does not matter. Writing to this tag does not cause an explicit write to the device. It is used in an Object Group 12 control operation on binary output point 2 when the Operate.Set tag is toggled to 1.
10.0.2.Operate.OffTime	Value in milliseconds that the operation on the binary output point 2 remains non-active	This DWord tag displays the off time last updated from the client. The variation of the tag does not matter. Writing to this tag does not cause an explicit write to the device. It is used in an Object Group 12 control operation on binary output point 2 when the Operate.Set tag is toggled to 1.
10.0.2.Operate.FeedbackDelay	Value in milliseconds to delay after receiving the response before issuing feedback poll	This DWord tag displays the feedback delay last updated from the client. The variation of the tag does not matter. Writing to this tag does not cause an explicit write to the device. It is used to delay before issuing a feedback poll after receiving a response to an Object Group 12 control operation on binary output point 2.
10.0.2.Operate.Set	Always displays a Boolean value of 0 with good quality	The variation of the tag does not matter. Writing a 1 to this tag causes an Object Group 12 control operation on binary output point 2. The CROB control code is built from the values of the Operate.Clear, Operate.OpType, and Operate.TripCloseCode tags. The Values of the Operate.OnTime, Operate.OffTime, and Operate.FeedbackDelay tags are used in the operation as well.

Object Group 20 - Counters

The status for each point in an object group is retained on each transaction; all flags are reported in their sub-type tags. The corresponding event object may also return Time of Occurrence.

Note: Object Group 20 - Counter Value is reflected in Object Group 22 - Counter Event Change. For more information, refer to [Other Object Groups](#).

Attributes

The default data type is shown in **bold**.

OBJ.VAR.IDX Attributes	.SUB Attribute	Data Type	Access
20.{0,1,2,5,6}.{0-65535}	LocalForce, Lost, Online, RemoteForce, Restart	Boolean	Read Only
20.{0,1,2,5,6}.{0-65535}	Flags	Byte	Read Only
20.{0,1,2,5,6}.{0-65535}	Timestamp	Date	Read Only
20.0.{0-65535}	Value, Explicit	DWord	Read Only
20.1.{0-65535}	Value, Explicit	DWord	Read Only
20.2.{0-65535}	Value, Explicit	Word	Read Only
20.5.{0-65535}	Value, Explicit	DWord	Read Only
20.6.{0-65535}	Value, Explicit	Word	Read Only

Variations

Number	Description
0	Variation determined by slave device.
1	32-bit with Flag.
2	16-bit with Flag.
5	32-bit without Flag.
6	16-bit without Flag.

DNP Object Flag Definitions

If the device returns an exception bit set, the quality of the .Value or .Explicit tag is bad. The following available bits are exception bits, excluding Online. Descriptions are as follows:

- 0: Online
- 1: Restart
- 2: Communications Lost
- 3: Remote Force
- 4: Local Force
- 5: Rollover
- 6: Discontinuity
- 7: Reserved

Examples

Tag Address	Definition	Description
20.0.0.Value*	Value of point 0 as a DWord	This tag is updated from the datastore that is populated via responses to integrity and event polls. No explicit request is sent to the device. The slave can return variation 1, 2, 5, or 6; depending on its Object Group 22 default event variation. These all fit in a DWord.
20.0.5.Explicit	Value of point 5 as a DWord	An explicit request is sent to the device to get the value for this tag. Other Object Group 20 variation 0 Explicit tags are blocked with this tag in one request. The slave can return variation 1, 2, 5, or 6; depending on its default static variation. These all fit in a DWord.
20.1.10.Explicit	Value of point 10 as a DWord	An explicit request is sent to the device to get the value for this tag. Other Object Group 20 Variation 1 Explicit tags are blocked with this tag in one request.
20.1.10.Value*	Value of point 10 as a DWord	This tag is updated from the datastore that is populated via responses to integrity and event polls. No explicit request is sent to the device. The variation of 1 in the tag address sets the data type of the tag, but does not define the data type returned by the slave.

Tag Address	Definition	Description
		The slave uses its Object Group 22 default event variation.
20.2.10.Explicit	Value of point 10 as a Word	An explicit request is sent to the device to get the value for this tag. Other Object Group 20 variation 2 Explicit tags are blocked with this tag in one request.
20.0.8.Timestamp*	Event Time of Occurrence of point 8 (if an event has occurred and the time of occurrence was returned).	This tag is updated from the datastore that is populated via responses to integrity and event polls. No explicit request are sent to the device. This tag shows a timestamp of 1999-11-30T00:00:00 or 1899-12-30T00:00:00. They have bad quality until the device sends an event with the time. The Object Group 22 default event variation on the device needs to be 5 or 6 for it to return the event time of occurrence.
20.0.9.Flags*	Latest Flag byte for point 9.	This tag is updated from the datastore that is populated via responses to integrity and event polls or an explicit request for counter point 9. No explicit request is sent to the device. The value of this tag displays the latest flags' byte received for point 9 (regardless of the variation in the tag address).
20.0.3.Lost*	Latest state of bit 2 of the Flag byte for point 3.	This tag is updated from the datastore that is populated via responses to integrity and event polls or an explicit request for counter point 3. No explicit request is sent to the device. The value of this tag displays the state of bit 2 from the flags byte received for point 3 (regardless of the variation in the tag address).

*If an event time of occurrence is received with the event, then the tag's OPC timestamp should display the master's local time in which the event occurred within the slave. For more information, refer to [Communications](#).

Object Group 21 - Frozen Counters

The status for each point in an object group is retained on each transaction; all flags are reported in their sub-type tags. The corresponding event object may also return Time of Occurrence.

Note: Object Group 21 - Frozen Counter Value is reflected in Object Group 23 - Frozen Counter Event Change. For more information, refer to [Other Object Groups](#).

Attributes

The default data type is shown in **bold**.

OBJ.VAR.IDX Attributes	.SUB Attribute	Data Type	Access
21.{0,1,2,5,6,9,10}.{0-65535}	LocalForce, Lost, Online, RemoteForce, Restart	Boolean	Read Only
21.{0,1,2,5,6,9,10}.{0-65535}	Flags	Byte	Read Only
21.{0,1,2,5,6,9,10}.{0-65535}	Timestamp	Date	Read Only
21.0.{0-65535}	Value, Explicit	DWord	Read Only
21.1.{0-65535}	Value, Explicit	DWord	Read Only
21.2.{0-65535}	Value, Explicit	Word	Read Only
21.5.{0-65535}	Value, Explicit	DWord	Read Only
21.6.{0-65535}	Value, Explicit	Word	Read Only
21.9.{0-65535}	Value, Explicit	DWord	Read Only
21.10.{0-65535}	Value, Explicit	Word	Read Only

Variations

Number	Description
0	Variation determined by slave device
1	32-bit with Flag
2	16-bit with Flag
5	32-bit with Flag and Time
6	16-bit with Flag and Time
9	32-bit without Flag
10	16-bit without Flag

DNP Object Flag Definitions

If the device returns an exception bit set, the quality of the .Value or .Explicit tag is bad. The following available bits are exception bits, excluding Online. Descriptions are as follows:

- 0: Online
- 1: Restart
- 2: Communications Lost
- 3: Remote Force
- 4: Local Force
- 5: Rollover
- 6: Discontinuity
- 7: Reserved

Examples

Tag Address	Definition	Description
21.0.0.Value*	Value of point 0 as a DWord	This tag is updated from the datastore that is populated via responses to integrity and event polls. No explicit request is sent to the device. The slave can return variation 1, 2, 5, 6, 9, or 10; depending on its Object Group 23 default event variation. These all fit in a DWord.
21.0.5.Explicit	Value of point 5 as a DWord	An explicit request is sent to the device to get the value for this tag. Other object 21 variation 0 Explicit tags are blocked with this tag in one request. The slave can return variation 1, 2, 5, 6, 9, or 10; depending on its default static variation. These all fit in a DWord.
21.1.10.Explicit	Value of point 10 as a DWord	An explicit request is sent to the device to get the value for this tag. Other Object 21 Variation 1 Explicit tags are blocked with this tag in one request.
21.1.10.Value*	Value of point 10 as a DWord	This tag is updated from the datastore that is populated via responses to integrity and event polls. No explicit request is sent to the device. The variation of 1 in the tag address sets the data type of the tag, but does not define the data type returned by the slave. The slave uses its Object Group 23 default event variation.
21.2.10.Explicit	Value of point 10 as a Word	An explicit request is sent to the device to get the value for this tag. Other Object 21 Variation 2 Explicit tags are blocked with this tag in one request.
21.0.8.Timestamp*	Event Time of Occurrence of point 8 (if an event has occurred and the time of occurrence was returned)	This tag is updated from the datastore that is populated via responses to integrity and event polls. No explicit request is sent to the device. This tag shows a timestamp of 1999-11-30T00:00:00 or 1899-12-30T00:00:00. It has bad quality until the device sends an event with the time. The Object Group 23 default event variation on the device needs to be 5 or 6 for it to return the event time of occurrence.
21.0.9.Flags*	Latest Flag byte for point 9	This tag is updated from the datastore that is populated via responses to integrity and event polls or an explicit request for frozen counter point 9. No explicit request is sent to the device. The value of this tag displays the latest flags' byte received for point 9 (regardless of the variation in the tag address).
21.0.3.Lost*	Latest state of bit 2 of the Flag byte for point 3	This tag is updated from the datastore that is populated via responses to integrity and event polls or an explicit request for frozen counter point 3. No explicit request is sent to the device. The value of this tag displays the state of bit 2 from the flags byte received for point 3 (regardless of the variation in the tag address).

*If an event time of occurrence is received with the event, then the tag's OPC timestamp should display the master's local time in which the event occurred within the slave. For more information, refer to [Communications](#).

Object Group 30 - Analog Inputs

The status for each point in an object group is retained on each transaction; all flags are reported in their sub-type tags. The corresponding event object may also return Time of Occurrence.

Note: Object Group 30 - Analog Input Value is reflected in Object Group 32 - Analog Input Change Event. For more information, refer to [Other Object Groups](#).

Attributes

The default data type is shown in **bold**.

OBJ.VAR.IDX Attributes	.SUB Attribute	Data Type	Access
30.{0,1,2,3,4,5,6}.{0-65535}	LocalForce, Lost, Online, RemoteForce, Restart, OverRange, ReferenceCheck	Boolean	Read Only
30.{0,1,2,3,4,5,6}.{0-65535}	Flags	Byte	Read Only
30.{0,1,2,3,4,5,6}.{0-65535}	Timestamp	Date	Read Only
30.0.{0-65535}	Value, Explicit	Double	Read Only
30.1.{0-65535}	Value, Explicit	Long	Read Only
30.2.{0-65535}	Value, Explicit	Short	Read Only
30.3.{0-65535}	Value, Explicit	Long	Read Only
30.4.{0-65535}	Value, Explicit	Short	Read Only
30.5.{0-65535}	Value, Explicit	Float	Read Only
30.6.{0-65535}	Value, Explicit	Double	Read Only

Variations

Number	Description
0	Variation determined by slave device
1	32-bit with Flag
2	16-bit with Flag
3	32-bit without Flag
4	16-bit without Flag
5	32-bit floating-point with Flag
6	64-bit floating-point with Flag

DNP Object Flag Definitions

If the device returns an exception bit set, the quality of the .Value or .Explicit tag is bad. The following available bits are exception bits, excluding Online. Descriptions of the available bits are as follows:

- 0: Online
- 1: Restart
- 2: Communications Lost
- 3: Remote Force
- 4: Local Force
- 5: Overrange
- 6: Reference Check
- 7: Reserved

Examples

Tag Address	Definition	Description
30.0.0.Value*	Value of point 0 as a Double	This tag is updated from the datastore that is populated via responses to integrity and event polls. No explicit request is sent to the device. The slave can return variation 1, 2, 3, 4, 5, or 6; depending on its Object Group 32 default event variation. These fit in a Double.
30.0.5.Explicit	Value of point 5 as a Double	An explicit request is sent to the device to get the value for this tag. Other object 30 variation 0 Explicit tags are blocked with this tag in one request. The slave can return variation 1, 2, 3, 4, 5, or 6; depending on its default static variation. These fit in a Double.
30.1.10.Explicit	Value of point 10 as a DWord	An explicit request is sent to the device to get the value for this tag. Other object 30 variation 1 Explicit tags are blocked with this tag in one request.
30.1.10.Value*	Value of point 10 as a DWord	This tag is updated from the datastore that is populated via responses to integrity and event polls. No explicit request is sent to the device. The variation of 1 in the tag address sets the data type of the tag, but

Tag Address	Definition	Description
		does not define the data type returned by the slave. The slave uses its Object Group 32 default event variation. If the slave is returning a floating-point value using Object Group 32 variations 5, 6, 7, or 8, this tag only displays the integer part of the value of the point.
30.2.10.Explicit	Value of point 10 as a Word	An explicit request is sent to the device to get the value for this tag. Other object 30 variation 2 Explicit tags are blocked with this tag in one request.
30.0.8.Timestamp*	Event Time of Occurrence of point 8 (if an event has occurred and the time of occurrence was returned)	This tag is updated from the datastore that is populated via responses to integrity and event polls. No explicit request is sent to the device. This tag shows a timestamp of 1999-11-30T00:00:00 or 1899-12-30T00:00:00. It has bad quality until the device sends an event with the time. The Object Group 32 default event variation on the device needs to be 3, 4, 7, or 8 for it to return the event time of occurrence.
30.0.9.Flags*	Latest Flag byte for point 9	This tag is updated from the datastore that is populated via responses to integrity and event polls or an explicit request for analog input point 9. No explicit request is sent to the device. The value of this tag displays the latest flags' byte received for point 9 (regardless of the variation in the tag address).
30.0.3.Lost*	Latest state of bit 2 of the Flag byte for point 3	This tag is updated from the datastore that is populated via responses to integrity and event polls or an explicit request for analog input point 3. No explicit request is sent to the device. The value of this tag displays the state of bit 2 from the flags byte received for point 3 (regardless of the variation in the tag address).

*If an event time of occurrence is received with the event, then the tag's OPC timestamp should display the master's local time in which the event occurred within the slave. For more information, refer to [Communications](#).

Object Group 34 - Analog Inputs Deadband

These tags are only read explicitly once after start up. Explicit reads of the same object group and Variation are blocked together: A block that contains a failed tag continues to be read until the tag's quality changes to good or is removed.

Attributes

The default data type is shown in **bold**.

OBJ.VAR.IDX Attributes	.SUB Attribute	Data Type	Access
34.0.{0-65535}	Value, Explicit	DWord	Read/Write
34.1.{0-65535}	Value, Explicit	Word	Read/Write
34.2.{0-65535}	Value, Explicit	DWord	Read/Write
34.3.{0-65535}	Value, Explicit	Float	Read/Write

Variations

Number	Description
0	Variation determined by slave device*
1	16-bit
2	32-bit
3	32-bit floating-point

*Variation 0 is used to request the default variation.

Examples

Tag Address	Definition	Description
34.0.0.Value	Deadband Value of analog input point 0 as a DWord	If a value for this tag has not been received from the device, then an explicit request is sent. The slave can return variation 1, 2, or 3; depending on its Object 34 default variation. These all fit in a DWord. Once the point

Tag Address	Definition	Description
		has been initialized, the tag receives updates from the datastore. A second explicit request is only issued if the slave or master restarts. Other Object 34 variation 0 Explicit and Value tags are blocked with this tag in one request.
34.0.5.Explicit	Deadband Value of analog input point 5 as a DWord	If a value for this tag has not been received from the device, then an explicit request is sent. The slave can return variation 1, 2, or 3; depending on its Object 34 default variation. These all fit in a DWord. Once the point has been initialized, the tag receives updates from the datastore. A second explicit request is only issued if the slave or master restarts. Other Object 34 variation 0 Explicit and Value tags are blocked with this tag in one request.
34.1.10.Explicit	Deadband Value of analog input point 10 as a Word	If a value for this tag has not been received from the device, then an explicit request is sent. Once the point has been initialized, the tag receives updates from the datastore. A second explicit request is only issued if the slave or master restarts. Other Object 34 variation 1 Explicit and Value tags are blocked with this tag in one request.
34.1.10.Value	Deadband Value of analog input point 10 as a Word	If a value for this tag has not been received from the device, then an explicit request is sent. Once the point has been initialized, the tag receives updates from the datastore. A second explicit request is only issued if the slave or master restarts. Other Object 34 variation 2 Explicit and Value tags are blocked with this tag in one request.
34.2.10.Explicit	Deadband Value of analog input point 10 as a DWord	If a value for this tag has not been received from the device, then an explicit request is sent. Once the point has been initialized, the tag receives updates from the datastore. A second explicit request is only issued if the slave or master restarts. Other Object 34 variation 2 Explicit and Value tags are blocked with this tag in one request.

Object Group 40 - Analog Outputs

The status for each point in an object group is retained on each transaction; all flags are reported in their sub-type tags. The corresponding event object may also return Time of Occurrence.

Note: Object Group 40 - Analog Output Value is reflected in Object Group 41 - Analog Output Write, Object Group 42 - Analog Output Change Event, and Object Group 43 - Analog Output Command Event. For more information, refer to [Other Object Groups](#).

See Also: [Object Group 41 - Analog Output Commands](#)

Variations

The default data type is shown in **bold**.

OBJ.VAR.IDX Attributes	.SUB Attribute	Data Type	Access
40.{0,1,2,3,4}.{0-65535}	LocalForce, Lost, Online, RemoteForce, Restart, OverRange, ReferenceCheck	Boolean	Read Only
40.{0,1,2,3,4}.{0-65535}	DO, SO	Boolean	Read/Write
40.{0,1,2,3,4}.{0-65535}	Flags	Byte	Read Only
40.{0,1,2,3,4}.{0-65535}	Timestamp	Date	Read Only
40.0.{0-65535}	Value, Explicit	Double	Read/Write
40.1.{0-65535}	Value, Explicit	Long	Read/Write
40.2.{0-65535}	Value, Explicit	Short	Read/Write
40.3.{0-65535}	Value, Explicit	Float	Read/Write
40.4.{0-65535}	Value, Explicit	Double	Read/Write

Variations

Number	Description
0	Status - Variation determined by slave device*
1	Status 32-bit with Flag
2	Status 16-bit with Flag
3	Status 32-bit floating-point with Flag
4	Status 64-bit floating-point with Flag

*Variation 0 is used to request the default variation.

DNP Object Flag Definitions

If the device returns an exception bit set, the quality of the .Value or .Explicit tag is bad. The following available bits are exception bits, excluding online. Descriptions are as follows:

- 0: Online
- 1: Restart
- 2: Communications Lost
- 3: Remote Force
- 4: Local Force
- 5: Overrange
- 6: Reference Check
- 7: Reserved

Examples

Tag Address	Definition	Description
40.0.0.Value*	Value of point 0 as a Double	This tag is updated from the datastore that is populated via responses to integrity and event polls. No explicit request is sent to the device. The slave can return variation 1, 2, 3, 4, 5, 6, 7, or 8; depending on its Object Group 42 default event variation. These all fit in a Double.
40.0.5.Explicit	Value of point 5 as a Double	An explicit request is sent to the device to get the value for this tag. Other object 40 variation 0 Explicit tags are blocked with this tag in one request. The slave can return variation 1, 2, 3, or 4; depending on its default static variation. These all fit in a Double.
40.1.10.Explicit	Value of point 10 as a DWord	An explicit request is sent to the device to get the value for this tag. Other object 40 variation 1 Explicit tags are blocked with this tag in one request.
40.1.10.Value*	Value of point 10 as a DWord	This tag is updated from the datastore that is populated via responses to integrity and event polls. No explicit request is sent to the device. The variation of 1 in the tag address sets the data type of the tag, but does not define the data type returned by the slave. The slave uses its Object Group 42 default event variation. If the slave is returning a floating-point value using Object Group 42 variations 5, 6, 7, or 8, this tag only displays the integer part of the value of the point.
40.2.10.Explicit	Value of point 10 as a Word	An explicit request is sent to the device to get the value for this tag. Other object 40 variation 2 Explicit tags are blocked with this tag in one request.
40.0.8.Timestamp*	Event Time of Occurrence of point 8 (if an event has occurred and the time of occurrence was returned)	This tag is updated from the datastore that is populated via responses to integrity and event polls. No explicit request is sent to the device. This tag shows a timestamp of 1999-11-30T00:00:00 or 1899-12-30T00:00:00. It has bad quality until the device sends an event with the time. The Object Group 42 default event variation on the device needs to be 3, 4, 7, or 8 for it to return the event time of occurrence.
40.0.9.Flags*	Latest Flag byte for point 9	This tag is updated from the datastore that is populated via responses to integrity and event polls or an explicit request for analog output point 9. No explicit request is sent to the device. The value of this tag displays the latest flags' byte received for point 9 (regardless of the variation in the tag address).

Tag Address	Definition	Description
40.0.3.Lost*	Latest state of bit 2 of the Flag byte for point 3	This tag is updated from the datastore that is populated via responses to integrity and event polls or an explicit request for analog output point 3. No explicit request is sent to the device. The value of this tag displays the state of bit 2 from the flags byte received for point 3 (regardless of the variation in the tag address).
40.0.2.DO*	Boolean value indicating if operations on analog output point 2 should be Direct Operate or Select then Operate	Writing to this tag does not cause an explicit write to the device. It also does not change the overall device property for operate Mode. It only changes it for Analog Output point 2. The variation of the tag does not matter. The value of this tag is used when an operation is performed on analog output point 2 using a synchronous or asynchronous write to a 40.x.2.Value or 40.x.2.Explicit tag.
40.0.2.SO*	Boolean value indicating if operations on analog output point 2 should be Direct Operate or Select then Operate	Writing to this tag does not cause an explicit write to the device. It also does not change the overall device property for operate Mode. It only changes it for Analog Output point 2. The variation of the tag does not matter. The value of this tag is used when an operation is performed on analog output point 2 using a synchronous or asynchronous write to a 40.x.2.Value or 40.x.2.Explicit tag.

*If an event time of occurrence is received with the event, then the tag's OPC timestamp should display the master's local time in which the event occurred within the slave. For more information, refer to [Communications](#).

Object Group 41 - Analog Output Commands

Issuing an Analog Output Command

To issue an analog output command, execute a synchronous or an asynchronous write to a 40.x.x.Value or a 40.x.x.Explicit tag. Depending on the Feedback Poll after Operate device property, another request may be sent after the actual operate request to obtain the latest value of all analog output points. If the operate is successful but the feedback poll fails, the device reports status code 4. For more information, refer to [Advanced](#).

See Also: [Unable to write to address <address> on device <device>. Control-Related Status Code <status code>.](#)

Function Codes

The function code used in the write request depends on the setting of the overall device property for operate Mode and/or any 40.x.x.DO or 40.x.x.SO tags. The Select-then-Operate option sends two requests - the first with the select function code (3) followed by a request with the operate function code (4). The Direct-Operate option sends one request with the direct operate function code (5). For more information on the operate Mode device property, refer to [Advanced](#).

Note: For more information on the DO and SO sub-type, refer to [Object Group 40 - Analog Outputs](#).

Object Group 50 - Time and Date

Object Group 50 is the slave's clock. Since it cannot be read through unsolicited replies, the DNP3 Master Serial Driver must explicitly request a read. The driver requests a read every time the tag is pulled for an update because it's a time datum. On a default instantiation, this occurs every 200 ms. To avoid congesting the communications link, create a separate OPC group for the Object Group 50 time tag. Then, set that group's update rate to 1000 ms or slower.

Note: Object Group 50 - Time and Date is reflected in Object Group 51 - Time and Date Common Time of Occurrence (CTO). For more information, refer to [Other Object Groups](#).

Attributes

The default data type is shown in **bold**.

OBJ.VAR Attributes	.SUB Attribute	Data Type	Access
50.0	Value, Explicit	Date	Read Only
50.1	Value, Explicit	Date	Read Only

Note: Flags do not apply.

Variations

Number	Description
0	Time and Data Absolute time*
1	Time and Date Absolute time

*Allowed, but same as 50.1.

Examples

Tag Address	Definition	Description
50.0.Value	Date and time saved in the slave	An explicit request for object 50 variation 1 is sent to the device to get the value for this tag. The update rate should not be set too often since it causes traffic every time the tag needs to be updated.
50.1.Value	Date and time saved in the slave	An explicit request for object 50 variation 1 is sent to the device to get the value for this tag. The update rate should not be set too often since it causes traffic every time the tag needs to be updated.
50.0.Explicit	Date and time saved in the slave	An explicit request for object 50 variation 1 is sent to the device to get the value for this tag. The update rate should not be too set often since it causes traffic every time the tag needs to be updated.
50.1.Explicit	Date and time saved in the slave	An explicit request for object 50 variation 1 is sent to the device to get the value for this tag. The update rate should not be set too often since it causes traffic every time the tag needs to be updated.

Object Group 60 - Class Poll Data Request

When a Boolean True is written to these tags, Object Group 60 variations 1-4 initiate class 0-3 reads (respectively). Object Group 60 tags can be used to 'manually' poll when the recommended event and integrity class polling intervals cannot be used. This approach is not recommended, however, because care must be taken to keep the requests in proper order. An integrity poll polls class 1, 2, 3, and 0 in that order, in one request, and without time lapses in between.

When using the Object Group 60 tags to poll for events, users should poll the event classes (variations 2, 3, and 4) before polling for class 0 static data (variation 1). This ensures that event data is received in the correct order and that the latest value is received after preceding events. Although a class Object Group 60.1 request can be issued immediately after any of the event class Object Group 60.2, 3, or 4 requests, these are still separate requests. Users risk losing any events that occurred between the last class 1, 2, or 3 request and the class 0 request. A read of these tags always returns a Boolean false with good quality.

Attributes

These tags trigger commands on the DNP slave device when a True value is written. They read back as zero or False.

OBJ.VAR Attributes	.SUB Attribute	Data Type	Access
60.{1}	Value, Explicit	Boolean	Read/Write
60.{2}	Value, Explicit	Boolean	Read/Write
60.{3}	Value, Explicit	Boolean	Read/Write
60.{4}	Value, Explicit	Boolean	Read/Write

Note: Flags do not apply.

Variations

Number	Description
1	Initiates a poll of DNP Class 0 data
2	Initiates a poll of DNP Class 1 data
3	Initiates a poll of DNP Class 2 data
4	Initiates a poll of DNP Class 3 data

Examples

Tag Address	Definition	Description
60.1.Value	Always displays a Boolean value of 0 with good quality	Writing a 1 to this tag initiates a request for Class 0 data. The sub-type can be Value or Explicit.
60.2.Value	Always displays a Boolean value of 0 with good quality	Writing a 1 to this tag initiates a request for Class 1 data. The sub-type can be Value or Explicit.
60.3.Explicit	Always displays a Boolean value of 0 with good quality	Writing a 1 to this tag initiates a request for Class 2 data. The sub-type can be Value or Explicit.
60.4.Explicit	Always displays a Boolean value of 0 with good quality	Writing a 1 to this tag initiates a request for Class 3 data. The sub-type can be Value or Explicit.

Object Group 70 - File Identifiers

Attributes

OBJ.IDX Attributes	.SUB Attributes	Data Type	Access
70.0-9	Download, Upload	Boolean	Read/Write
70.0-9	LocalFileName, RemoteFileName	String	Read/Write

Note: Flags do not apply.

Examples

Tag Address	Definition	Description
70.0.Upload	Displays the current status of a file transfer upload for the file settings configured for index 0. 0: No file transfer upload in progress 1: Upload in progress	Writing a 1 to this tag causes a file transfer of the remote file on the slave to the local file on the master. The file identifiers are built from the path and the file name properties. If the path does not already end in a backslash or forward slash, one is added before the file name. The tag displays a 1 until the transfer completes (at which time the tag displays a 0). If an upload is in progress, writing a 0 to this tag causes the file transfer to be aborted.
70.5.Download	Displays the current status of a file transfer download for the file settings configured for index 5. 0: No file transfer download in progress 1: Download in progress	Writing a 1 to this tag causes a file transfer of the local file on the master to the remote file on the slave. The file identifiers are built from the path and the file name properties. If the path does not already end in a backslash or forward slash, one is added before the file name. The tag displays a 1 until the transfer completes (at which time, the tag displays a 0). If a download is in progress, writing a 0 to this tag causes the file transfer to be aborted.
70.6.LocalFileName	Displays the currently configured local file name from the device property File Control tab for index 6	This tag is read only unless the device Property for file Name writes is set to Yes. If the tag has read/write access, writing to this tag updates the corresponding File Control device property. The contents of the local file name property is appended to the local path to build the file identifier. A backslash or forward slash separates the path from the file name.
70.8.RemoteFileName	Displays the currently configured remote file name from the device property File Control tab for index 8	This tag is read only unless the device Property for file name writes is set to Yes. If the tag has read/write access, writing to this tag updates the corresponding File Control device property. The contents of the remote file name property is appended to the remote path to build the file identifier. A backslash or forward slash separates the path from the file name.

Object Group 80 - Internal

Attributes

The default data type is shown in **bold**.

OBJ.VAR Attributes	.SUB Attribute	Data Type	Access
80.{0}	Value, Explicit	Word	Read Only
80.{1}	Value, Explicit	Word	Read Only

Note: Flags do not apply.

Variations

Number	Description
0	Internal Indications Packed format*
1	Internal Indications packed format

*Allowed, but same as 80.1.

IIN Definitions

Object Group 80 returns the DNP Internal Indication bits (IIN) as an unsigned short integer. The data is refreshed with each response from the DNP slave, and therefore represents the latest IIN report.

Internal Indication	Bit Mask	Reason
DNPDEFS_IIN_RESTART	0x8000	Slave has been restarted.
DNPDEFS_IIN_TROUBLE	0x4000	Slave is reporting trouble.
DNPDEFS_IIN_LOCAL	0x2000	Slave is running in local mode.
DNPDEFS_IIN_NEED_TIME	0x1000	Slave requires time synchronization.
DNPDEFS_IIN_CLASS_3	0x0800	Slave has Class 3 data available.
DNPDEFS_IIN_CLASS_2	0x0400	Slave has Class 2 data available.
DNPDEFS_IIN_CLASS_1	0x0200	Slave has Class 1 data available.
DNPDEFS_IIN_ALL_STATIONS	0x0100	The message was directed to the DNP broadcast address.
DNPDEFS_IIN_BAD_CONFIG	0x0020	Slave is misconfigured.
DNPDEFS_IIN_ALREADY_EXECUTING	0x0010	Slave has received a duplicate request.
DNPDEFS_IIN_BUFFER_OVFL	0x0008	Slave has lost one or more event reports.
DNPDEFS_IIN_OUT_OF_RANGE	0x0004	Command received references a non-existent I/O point.
DNPDEFS_IIN_OBJECT_UNKNOWN	0x0002	Command received references an unknown object.
DNPDEFS_IIN_BAD_FUNCTION	0x0001	Command received is not supported.

Examples

Tag Address	Definition	Description
80.0.Value	Latest Value of the two IIN bytes as a Word	The slave's response to every request includes two internal indication bytes. The bits of these bytes have special meanings as defined by the DNP specification. This tag displays the IIN bytes received in the last response from the device. This is read from the datastore and does not send an explicit request. The sub-type can be Value or Explicit; the variation can be 0 or 1. It makes no difference.
80.1.Explicit	Latest Value of the two IIN bytes as a Word	The slave's response to every request includes two internal indication bytes. The bits of these bytes have special meanings as defined by the DNP spec. This tag displays the IIN bytes received in the last response from the device. This is read from the datastore and does not send an explicit request. The sub-type can be Value or Explicit; the variation can be 0 or 1. It makes no difference.

Object Group 87 - Data Sets

.Value tags are populated by the data received from unsolicited events or integrity and event class polling.

.Explicit tags cause a device read: because tags for one set are blocked together, there is only one device read for the entire data set.

Note 1: At this time, data sets can only be defined in the slave. Users that manually create tags must define the correct data types. The master obtains the description of the data sets from the slave to automatically define tags.

Note 2: Object Group 88 - Data Set - Snapshot data is reflected in Object Group 87 - Data Set - Present Value tags. For more information, refer to [Other Object Groups](#).

Attributes

Variations for Object Group 87 do not equate to specific data types. Users must configure the tag with the same data type that is configured in the slave for the specific data set element. Descriptions of the attributes are as follows:

- **VAR:** This attribute indicates the particular element of the data set.
- **IDX:** This attribute indicates the particular data set that is defined in the device.

The default data type is shown in **bold**.

OBJ.VAR.IDX Attributes	.SUB Attribute	Data Type	Access
87.{0-1}.{0-65535}	Value, Explicit	Byte, Char, Date, Double, DWord , Float, Long, Short, String, Word	Read Only
87.{2-32}.{0-65535}	Value, Explicit	Byte, Char, Date, Double, DWord , Float, Long, Short, String, Word	Read/Write
87.{0}.{0-65535}	Set	Boolean	Read/Write

Variations

DNP Object Flag Definitions

To get a data point's flags, the slave's definition of the data set must include an element specifically for DNP flags.

Examples

Tag Address	Definition	Description
87.5.1.Explicit	Displays the fifth element of data set 1	The .Explicit sub-type indicates that a request to the device for all elements of data set 1 occurs every time the tag needs to be updated.
87.7.2.Value	Displays the seventh element of data set 2	The .Value sub-type indicates the tags for data set 2 is only updated from the datastore populated through unsolicited messages or integrity and event polls.
87.0.2.Set	Always displays a Boolean value of 0 with good quality	Writing a 1 to this tag causes an Object Group 87 write operation on data set 2. The write only takes place if there is data pending to be written due to a previous write to other .Value or .Explicit tags of this data set.

Object Group 110 - Octet String Object

These tags are only read explicitly once after start up. Explicit reads of the same object group and Variation are blocked together: A block that contains a failed tag continues to be read until the tag's quality changes to good or is removed.

Notes:

1. Object group 110 - Octet String value is reflected in object group 111 - Octet String Event Change. For more information, refer to [Other Object Groups](#).
2. Zero-length string tags return bad quality.

Attributes

The default data type is shown in **bold**.

OBJ.IDX Attributes	.SUB Attribute	Data Type	Access
110.{0-65535}	Value, Explicit - takes up to 255 chars.	String	Read/Write

Note: Flags do not apply.

Variations

Number	Description
String Length	Octet string

Examples

Tag Address	Definition	Description
110.0.Value	Value of point 0 as a string	If a value for this tag has not been received from the device, then an explicit request is sent. Once the point has been initialized, the tag receives updates from the datastore. A second explicit request is only issued if the slave or master restarts. Other Object 110 Explicit and Value tags are blocked with this tag in one request. The sub-type can be Value or Explicit: it makes no difference.
110.5.Explicit	Value of point 5 as a string	If a value for this tag has not been received from the device, an explicit request is sent. Once the point has been initialized, the tag receives updates from the datastore. A second explicit request is only issued if the slave or master restarts. Other Object 110 Explicit and Value tags are blocked with this tag in one request. The sub-type can be Value or Explicit: it makes no difference.

Object Group 120 - Authentication Object

The authentication object tags are internal statistics for DNP authentication.

Attributes

The default data type is shown in **bold**.

OBJ.VAR Attributes	.SUB Attribute	Description	Data Type	Access
120.KeyStatRQTX	Value Reset	Key status requests sent to outstation	DWord Bool	Read Only Read/Write
120.KeyStatRQRX	Value Reset	Key status responses received from outstation	DWord Bool	Read Only Read/Write
120.KeyStatRQRX_NoInit	Value Reset	Key status request responded with an uninitialized failure	DWord Bool	Read Only Read/Write
120.KeyStatRQRX_CommFail	Value Reset	Key status request responded with a communications failure	DWord Bool	Read Only Read/Write
120.KeyStatRQRX_AuthFail	Value Reset	Key status request responded with an authentication failure	DWord Bool	Read Only Read/Write
120.KeyChangeTX	Value Reset	Key change requests sent to the outstation	DWord Bool	Read Only Read/Write
120.AggrModeRQTX	Value Reset	Aggressive mode requests sent to the outstation	DWord Bool	Read Only Read/Write
120.AggrModeResponseRX	Value Reset	Aggressive mode responses from the outstation	DWord Bool	Read Only Read/Write
120.AggrModeResponseRX_Failed	Value Reset	Aggressive mode request responded with a failure	DWord Bool	Read Only Read/Write
120.ChallRQTX	Value Reset	Challenge requests sent to the outstation	DWord Bool	Read Only Read/Write
120.ChallRQRX	Value Reset	Challenge requests received from the outstation	DWord Bool	Read Only Read/Write
120.CriticalChallRQTX	Value Reset	Critical challenge requests sent to the outstation	DWord Bool	Read Only Read/Write
120.CriticalChallRQRX	Value Reset	Critical challenge requests received from the outstation	DWord Bool	Read Only Read/Write
120.ChallReplyTX	Value Reset	Challenge responses sent to the outstation	DWord Bool	Read Only Read/Write
120.ChallReplyRX	Value Reset	Challenge responses received from the outstation	DWord Bool	Read Only Read/Write
120.ChallReplyRX_Failed	Value Reset	Challenge responses with a failure	DWord Bool	Read Only Read/Write
120.ErrorTX_Invalid	Value Reset	Invalid errors sent to outstation	DWord Bool	Read Only Read/Write
120.ErrorTX_	Value	Unexpected reply errors sent to	DWord	Read Only

OBJ.VAR Attributes	.SUB Attribute	Description	Data Type	Access
UnexpectedReply	Reset	outstation	Bool	Read/Write
120.ErrorTX_NoReply	Value Reset	No reply errors sent to outstation	DWord Bool	Read Only Read/Write
120.ErrorTX_AggrModeNotSupported	Value Reset	Aggressive mode not supported errors sent to outstation	DWord Bool	Read Only Read/Write
120.ErrorTX_HMACAlgNotSupported	Value Reset	HMAC algorithm not supported errors sent to outstation	DWord Bool	Read Only Read/Write
120.ErrorTX_KeyWrapAlgNotSupported	Value Reset	Key wrap algorithm not supported errors sent to outstation	DWord Bool	Read Only Read/Write
120.ErrorTX_UserAccessDenied	Value Reset	User access denied errors sent to outstation	DWord Bool	Read Only Read/Write
120.ErrorTX_KeyChangeDenied	Value Reset	Key change denied errors sent to outstation	DWord Bool	Read Only Read/Write
120.ErrorTX_InvalidSign	Value Reset	Invalid signature errors sent to outstation	DWord Bool	Read Only Read/Write
120.ErrorTX_InvalidCert	Value Reset	Invalid certificate errors sent to outstation	DWord Bool	Read Only Read/Write
120.ErrorTX_UnknownUser	Value Reset	Unknown user errors sent to outstation	DWord Bool	Read Only Read/Write
120.ErrorTX_VendorSpecific	Value Reset	Vendor specific errors sent to outstation	DWord Bool	Read Only Read/Write
120.ErrorRX_Invalid	Value Reset	Invalid errors received from outstation	DWord Bool	Read Only Read/Write
120.ErrorRX_UnexpectedReply	Value Reset	Unexpected reply errors received from outstation	DWord Bool	Read Only Read/Write
120.ErrorRX_NoReply	Value Reset	No reply errors received from outstation	DWord Bool	Read Only Read/Write
120.ErrorRX_AggrModeNotSupported	Value Reset	Aggressive mode not supported errors received from outstation	DWord Bool	Read Only Read/Write
120.ErrorRX_HMACAlgNotSupported	Value Reset	HMAC algorithm not supported errors received from outstation	DWord Bool	Read Only Read/Write
120.ErrorRX_KeyWrapAlgNotSupported	Value Reset	Key wrap algorithm not supported errors received from outstation	DWord Bool	Read Only Read/Write
120.ErrorRX_UserAccessDenied	Value Reset	User access denied errors received from outstation	DWord Bool	Read Only Read/Write
120.ErrorRX_KeyChangeDenied	Value Reset	Key change denied errors received from outstation	DWord Bool	Read Only Read/Write
120.ErrorRX_InvalidSign	Value Reset	Invalid signature errors received from outstation	DWord Bool	Read Only Read/Write
120.ErrorRX_InvalidCert	Value Reset	Invalid certificate errors received from outstation	DWord Bool	Read Only Read/Write
120.ErrorRX_UnknownUser	Value Reset	Unknown user errors received from outstation	DWord Bool	Read Only Read/Write
120.ErrorRX_VendorSpecific	Value Reset	Vendor specific errors received from outstation	DWord Bool	Read Only Read/Write

Examples

Tag Address	Definition	Description
120.KeyStatRQTX.Value	Value of the KeyStatRQTX authentication statistic.	The number of key status requests sent to the outstation since startup or last reset.
120.KeyStatRQTX.Reset	Reset the KeyStatRQTX authentication statistic.	The KeyStatRQTX statistic is cleared with a write value of 1.

Other Object Groups

Certain objects are not used in the driver due to the fact that their values are reflected in other objects.

Object	Name	Reflected in Object	Name
2	Binary Input Change Event	1	Binary Input State
4	Double-Bit Input Change Event	3	Double-Bit Input State
11	Binary Output Change Event	10	Binary Output State
12	Control Relay Output Block	10	Binary Output State
13	Binary Output Command Event	10	Binary Output State
22	Counter Event Change	20	Counter Value
23	Frozen Counter Event Change	21	Frozen Counter Value
32	Analog Input Change Event	30	Analog Input Value
41	Analog Output Write	40	Analog Output Value
42	Analog Output Change Event	40	Analog Output Value
43	Analog Output Command Event	40	Analog Output Value
51	Time and Date Common Time of Occurrence (CTO)	50	Time and Date
88	Data Set - Snapshot	87	Data Set - Present Value
111	Octet String Event Change	110	Octet String Value

Internal Tags

Tag	Description	Data Type	Access
_AuthCurrentUserNumber	This tag allows the Authentication Current User Number device property to be changed from a client application. Valid values range from 0 to 65535.	Word	Read/Write
_ChannelResponseTimeout	This tag allows the Request Timeout channel property to be changed from a client application. Valid values range from 100 to 3600000.	DWord	Read/Write
_EventClass1PollInterval*	This tag allows the Event Class Poll 1 Interval device property to be changed from a client application. Valid values range from 0 to 86400 seconds.	DWord	Read/Write
_EventClass2PollInterval*	This tag allows the Event Class Poll 2 Interval device property to be changed from a client application. Valid values range from 0 to 86400 seconds.	DWord	Read/Write
_EventClass3PollInterval*	This tag allows the Event Class Poll 3 Interval device property to be changed from a client application. Valid values range from 0 to 86400 seconds.	DWord	Read/Write
_DeviceRequestQueueDepth	This tag indicates the current depth of the queue used for storing device requests. It is useful for diagnostic purposes for issues such as tag update delays. Although a zero or steady value is expected, a non-zero value is not a problem unless it continues to grow and causes a delay in tag updates. For example, if the project has a device defined with 100 blocks of .Explicit tags and the _DeviceRequestQueueDepth tag value is 100, then something is blocking the tags from being updated on time.	DWord	Read Only
_DeviceRequestTimeout	This tag allows the Request Timeout device property to be changed from a client application. Valid values range from 0 to 3600000.	DWord	Read/Write
_IntegrityPollInterval	This tag allows the Integrity Poll device property to be changed from a client application. Valid values range from 0 to 2592000.	DWord	Read/Write
_MasterAddress	This tag allows the master address device property to be changed from a client application. Valid values range from 0 to 65519.	DWord	Read/Write
_SlaveAddress	This tag allows the slave address device property to be changed from a client application. Valid values range from 0 to 65519.	DWord	Read/Write
_TimeSyncStyle	This tag allows the Time Synchronization Style device property to be changed from a client application. Valid values range from 0 to 1. A value of 0 indicates the	Byte	Read/Write

Tag	Description	Data Type	Access
	Serial Time Sync Style; a value of 1 indicates the LAN Time Sync Style.		

* Any write to this tag changes the units to seconds. There is currently no mechanism to change the units to milliseconds, minutes, or hours from an internal tag.

Special Tags

Tag	Description
ActivateConfig	When a Boolean True is written to this tag, an Activate Configuration Request is sent to the slave device. The tag is read back as zero or false and always has good quality.*
Coldrestart	When a Boolean true is written to this tag, a cold restart is sent to the slave device. The tag reads back as zero or false.
Unsolreceived	When Unsolicited Messaging is enabled for the device in the OPC server, the tag increments by 1 every time an unsolicited message is received from the slave. Note: This tag is read/write, so it can be reset to any value by the operator.
Warmrestart	When a Boolean True is written to this tag, a warm restart is sent to the slave device. The tag is read back as zero or false.

*The objects that are included in the request are defined in the Activate Config Objects parameter located in **Device Properties | File Control**. For more information, refer to [File Control](#).

Error Descriptions

The following categories of messages may be generated. Click on the link for a list of related messages.

[Address Validation](#)

[Authentication Error Messages](#)

[Automatic Tag Database Generation Messages](#)

[Device Status Messages](#)

[DNP Specific Error Messages](#)

[File Control Messages](#)

Address Validation

The following messages may be generated. Click on the link for a description of the message.

[Address <address> is not valid on device <channel> <device>.](#)

[Address <address> is out of range for the specified device or register.](#)

[Data type <type> is not valid for device address <address>.](#)

[Device address <address> contains a syntax error.](#)

[Device address <address> is read only.](#)

Address <address> is not valid on device <channel> <device>.

Error Type:

Warning

Possible Cause:

A scan tag with an invalid address was sent to the driver for initialization.

Solution:

Correct the address in the invalid tag.

Address <address> is out of range for the specified device or register.

Error Type:

Warning

Possible Cause:

A tag address that has been specified statically references a location that is beyond the range of supported locations for the device.

Solution:

Verify that the address is correct; if it is not, re-enter the address in the client application.

Data type <type> is not valid for device address <address>.

Error Type:

Warning

Possible Cause:

A tag address that has been specified statically has been assigned an invalid data type.

Solution:

Modify the requested data type in the client application.

Device address <address> contains a syntax error.

Error Type:

Warning

Possible Cause:

A tag address that has been specified statically contains one or more invalid characters.

Solution:

Re-enter the address in the client application.

Device address <address> is read only.

Error Type:

Warning

Possible Cause:

A tag address that has been specified statically has a requested access mode that is not compatible with what the device supports for that address.

Solution:

Change the access mode in the client application.

Authentication Error Messages

The following messages may be generated. Click on the link for a description of the message.

[Secure authentication failure on device <channel.device>. Device does not support the function code \(IIN2.0\).](#)

[Secure authentication failure on device <channel.device>. Key Status Request communications failure. Session keys are not valid.](#)

[Secure authentication failure on device <channel.device>. Key Status Request non-authentic. Session keys are not valid.](#)

[Secure authentication failure on device <channel.device>. Aggressive Mode response indicates improper authentication.](#)

[Secure authentication failure on device <channel.device>. Challenge Reply indicates improper authentication.](#)

[Secure authentication failure on device <channel.device>. User= <user number>, AssocID= <Association ID>, Sequence= <sequence number>. RX Error Code= <error code>-<error description>.](#)

[Secure authentication failure on device <channel.device>. User= <user number>, AssocID= <Association ID>, Sequence= <sequence number>. TX Error Code= <error code>-<error description>.](#)

[Secure authentication failure on device <device>. Key Status Request response status code: <status code>.](#)

Secure authentication failure on device <channel.device>. Device does not support the function code (IIN2.0).

Error Type:

Warning

Possible Cause:

The device is not configured to support authentication.

Solution:

Either uncheck the "Enable Authentication" parameter in device properties or enable authentication on the device.

Secure authentication failure on device <channel.device>. Key Status Request communications failure. Session keys are not valid.

Error Type:

Warning

Possible Cause:

1. The master and slave are not configured to match.
2. Either the master or the slave restarted, and the other is expecting a different session key.

Solution:

1. Ensure that the User Number/Update Key pairs on the master match those in the device.
2. Correct any invalid settings (such as KeyWrap Algorithm). Then, wait for the master to issue the key change request.

Secure authentication failure on device <channel.device>. Key Status Request non-authentic. Session keys are not valid.

Error Type:

Warning

Possible Cause:

The update keys do not match or there is another issue with encryption configuration.

Solution:

Correct the invalid update key for the current user number.

Secure authentication failure on device <channel.device>. Aggressive Mode response indicates improper authentication.

Error Type:

Warning

Possible Cause:

The Update Keys do not match or there is another issue with encryption configuration.

Solution:

Correct the invalid Update Key for the current User Number.

Secure authentication failure on device <channel.device>. Challenge Reply indicates improper authentication.

Error Type:

Warning

Possible Cause:

The Update Keys do not match or there is another issue with encryption configuration.

Solution:

Correct the invalid Update Key for the current User Number.

Note:

The slave rejected the critical request.

Secure authentication failure on device <channel.device>. User= <user number>, AssocID= <Association ID>, Sequence= <sequence number>. RX Error Code= <error code>-<error description>.

Error Type:

Warning

Possible Cause:

An error occurred when receiving a message.

Solution:

1. To determine the solution, refer to the code's error description.

Code Number	Description
1	Invalid Information
2	Unexpected Reply
3	No Reply
4	Aggressive Mode Not Supported
5	HMAC Algorithm Not Supported
6	Key Wrap Algorithm Not Supported
7	User Access Denied
8	Key Change Request Denied
9	Invalid Signature
10	Invalid Certification
11	Unknown User
128..255	Vendor Specific

2. When a user number is provided, it can be used to confirm that the user number and update key match in the master and slave.
3. When an Association ID is provided, it can be used to uniquely identify the association between the master and the slave on which the error occurred. This ID may correspond to different combinations of DNP addresses, IP addresses, and port numbers (or identifiers on the master and the slave).
4. When a sequence number is provided, it can be used to determine which request (such as a challenge or key change) had the authentication failure.

Secure authentication failure on device <channel.device>. User= <user number>, AssocID= <Association ID>, Sequence= <sequence number>. TX Error Code= <error code>-<error description>.

Error Type:

Warning

Possible Cause:

An error occurred when transmitting a message.

Solution:

1. To determine the solution, refer to the code's error description.

Code Number	Description
1	Invalid Information
2	Unexpected Reply
3	No Reply
4	Aggressive Mode Not Supported
5	HMAC Algorithm Not Supported
6	Key Wrap Algorithm Not Supported
7	User Access Denied
8	Key Change Request Denied
9	Invalid Signature
10	Invalid Certification
11	Unknown User
128..255	Vendor Specific

2. When a user number is provided, it can be used to confirm that the User Number and Update Key match in the master and slave.

3. When an Association ID is provided, it can be used to uniquely identify the association between the master and the slave on which the error occurred. This ID may correspond to different combinations of DNP addresses, IP addresses, and port numbers (or identifiers on the master and the slave).
4. When a sequence number is provided, it can be used to determine which request (such as a Challenge or Key Change) had the authentication failure.

Secure authentication failure on device <device>. Key Status Request response status code: <status code>.

Error Type:

Warning

Possible Cause:

An invalid status code was returned in the key status request response from the slave.

Solution:

The status code returned in the error message describes the status of the two session keys as known by the slave. If the status code is 0 ("not used") or 5-255 ("reserved for future use"), determine why the slave is responding with an unsupported status code in the Object Group 120 variation 5 response.

Automatic Tag Database Generation Messages

The following messages may be generated. Click on the link for a description of the message.

[Unable to add data set <data set index> on device <device name>. Data set has <number of elements> elements. The maximum number of elements allowed is <max. elements>.](#)

[Unable to generate a tag database for device <device>. Channel is not open.](#)

[Unable to generate a tag database for device <device>. Session is not open.](#)

[Unable to generate a tag database for device <device name>. Unable to open communications port.](#)

[Unable to generate a tag database for device <driver>. The device is not responding.](#)

[Unable to read device attribute set <set number>. No tags added on device <device>.](#)

Unable to add data set <data set index> on device <device name>. Data set has <number of elements> elements. The maximum number of elements allowed is <max. elements>.

Error Type:

Informational

Possible Cause:

The data set at the specified index has more than the maximum number of elements allowed.

Solution:

Reduce the data set's number of elements.

Unable to generate a tag database for device <device>. Channel is not open.

Error Type:

Warning

Possible Cause:

The driver was unable to initialize the communication stack.

Solution:

Reinitialize the driver by right-clicking on the Administration menu and then selecting **Reinitialize**. If the problem persists, restart the master.

Unable to generate a tag database for device <device>. Session is not open.

Error Type:

Warning

Possible Cause:

The driver was unable to initialize the communication stack.

Solution:

Reinitialize the driver by right-clicking on the Administration menu and then selecting **Reinitialize**. If the problem persists, restart the master.

Unable to generate a tag database for device <device name>. Unable to open communications port.

Error Type:

Warning

Possible Cause:

The specified communications port is unavailable.

Solution:

Choose the correct communications port, and then ensure it is available to the OPC server.

Unable to generate a tag database for device <driver>. The device is not responding.

Error Type:

Warning

Possible Cause:

1. The serial connection between the device and the host PC is broken.
2. The communication parameters for the serial connection are incorrect.
3. The named device may have been assigned an incorrect network ID.
4. A device on the channel is unresponsive, due to improper timing settings or a broken communications link.
5. There are multiple channels using DNS host names that resolve to the same IP address.

Solution:

1. Verify the cabling between the DNP master and the DNP slave device.
2. Verify that the specified communications parameters match those of the device.
3. Verify that the network ID given to the named device matches that of the actual device.
4. Locate the unresponsive device and then correct the timing settings or fix the broken communications link.
5. Ensure that all channels are using a unique destination host.

Unable to read device attribute set <set number>. No tags added on device <device>.

Error Type:

Warning

Possible Cause:

The device attribute set specified does not exist in the device.

Solution:

Deselect "Standard Device Attributes" and/or "User-Defined Device Attributes" in the Tag Import dialog.

Device Status Messages

The following messages may be generated. Click on the link for a description of the message.

[<item description> on device <device> has been auto-demoted.](#)
[<item description> on device <device> has been auto-promoted to determine if it can be completed.](#)
[Added <tag count> data set tag\(s\).](#)
[Data set write of value <value to be written> pending on tag address <address> on device <device>.](#)
[Device <device> does not support the LAN Time Sync Style Record Current Time Function Code 24.](#)
[Device <device> does not support the LAN Time Sync Style write to object group 50, variation 3.](#)
[Device <device> indicated an event buffer overflow \(IIN 2.3\).](#)
[Device <device> indicated it restarted \(IIN 1.7\).](#)
[Device <device> initialization completed.](#)
[Device <device> requested time synchronization \(IIN 1.4\).](#)
[Device <device> restarting.](#)
[Device <device name> is not responding.](#)
[Reached Max. Events Per Point for object group <object group> Point <data index> on device <device>.](#)
[Request failed on device <device>. Device does not support the function code \(IIN2.0\).](#)
[Request to enable unsolicited messaging failed on device <device>.](#)
[Unable to bind to local address \(IP: xxx.xxx.xxx.xxx, Source Port: x\).](#)
[Unable to read point\(s\) <OBJ.VAR.IDX> on device <device>. Failed to initialize communication stack.](#)
[Unable to read point\(s\) <OBJ.VAR.IDX> on device <device>. Internal error occurred.](#)
[Unable to read point\(s\) <OBJ.VAR.IDX - OBJ.VAR.IDX> on device <device>. Failed to initialize communication stack.](#)
[Unable to read point\(s\) <OBJ.VAR.IDX - OBJ.VAR.IDX> on device <device>. Internal error occurred.](#)
[Unable to read tag <tag address> on device <device>. Device indicates one or more exception conditions \(DNP flags byte=<hexadecimal byte> - <DNP flag exception list\).](#)
[Unable to receive response from device <device> within timeout. Either the request or response could not be completed or the response is invalid.](#)
[Unable to write to address <address> on device <device>. Failed to initialize communication stack.](#)
[Unable to write to address <address> on device <device>. Internal error occurred.](#)
[Write complete to data set <index> on device <device>](#)

<item description> on device <device> has been auto-demoted.

Error Type:

Warning

Possible Cause:

The device continues to set an IIN bit, which requires the master to do something (such as time synchronization or clear the device restart bit); however, the device is rejecting the master's attempts to do so. This is possibly due to an issue with the authentication settings. When a number of successive cycles of request timeouts and retries have occurred, the master stops trying for a period of time.

Solution:

Confirm that the authentication settings specified in the master match those specified in the slave.

<item description> on device <device> has been auto-promoted to determine if it can be completed.

Error Type:

Warning

Possible Cause:

A request that was previously demoted has been promoted so that the master can try to resend the request.

Solution:

If the request is successful, nothing needs to be done. If the item continues to be demoted, ensure that the authentication settings are correct.

Added <tag count> data set tag(s).

Error Type:

Informational

Possible Cause:

If the added tag count for data set tags is 0, possible causes may be as follows:

1. There are no data sets defined in the slave.
2. The slave has a mismatched configuration; that is, it may be reporting that it has more prototypes or descriptors than actually have elements defined. When the master requests the prototype or descriptor definition, the slave then responds with a parameter error because it doesn't have definitions for all of them.

Solution:

1. Either define the data set descriptors in the slave or uncheck the data set parameter in tag Import.
2. Correct the slave so that it reports the actual number of prototypes and descriptors that have elements defined.

Data set write of value <value to be written> pending on tag address <address> on device <device>.

Error Type:

Informational

Possible Cause:

A write occurred to a tag that references a data set element. The value is not displayed in the tag value, but is pending a write to the data set.

Solution:

The data set write is complete when a data set tag with the subtype .Set has Boolean true written to it.

Device <device> does not support the LAN Time Sync Style Record Current Time Function Code 24.

Error Type:

Warning

Possible Cause:

The device does not support function code 24 - LAN (which is the specified time synchronization method).

Solution:

In **Device Properties | Communications**, change the time synchronization setting to Serial.

Note:

Time synchronization is successful despite the error message. To prevent the error message from occurring, change the setting as described above.

Device <device> does not support the LAN Time Sync Style write to object group 50, variation 3.

Error Type:

Warning

Possible Cause:

The device does not support a write to Object Group 50, variation 3, which is used in the second part of the LAN time synchronization method.

Solution:

To prevent the error message from occurring, open **Device Properties** and then select the **Communications** tab. In **Time Sync Style**, select **Serial**.

Note:

Time synchronization is successful despite the error message.

Device <device> indicated an event buffer overflow (IIN 2.3).

Error Type:

Warning

Possible Cause:

A response from the device included IIN bytes along with the bit set, indicating that an event buffer overflow condition exists. At least one unconfirmed event was lost because the event buffers did not have enough room to store the information.

Solution:

1. If many events occur between event polls (and the bit is being set by the slave) decrease the event poll interval to keep the buffer size small.
2. To avoid logging unnecessary events, adjust the analog point deadband.

See Also:

[Event Playback](#)

Device <device> indicated it restarted (IIN 1.7).

Error Type:

Informational

Possible Cause:

A response from the device included IIN bytes along with the bit set. This indicates that the device restarted.

Solution:

N/A

Device <device> initialization completed.

Error Type:

Informational

Possible Cause:

1. The master has successfully communicated with the device, and the following requests have successfully completed (if configured):
 - Integrity poll on restart.
 - Data set change on startup.
 - Enable unsolicited messages.
 - Disable unsolicited messages.
2. When this message repeats frequently in the Event Log, it indicates that the master is repeatedly restarting. This may occur when channel serialization is in use, and the master receives a request from the slave when it does not have the channel token. If the connection was made using Ethernet Encapsulation, the slave may close the socket if it does not receive a response in the specified time.

Solution:

1. N/A
2. Determine why the master is restarting, and then correct the setup. If it is because the TCP slave is sending a request (such as a Link Status request, a Keep Alive request, or an unsolicited message) via Ethernet Encapsulation while channel serialization is in use, then the slave should be reconfigured to disable the requests or to increase the timeout (so that it does not close the socket).

Device <device> requested time synchronization (IIN 1.4).

Error Type:

Informational

Possible Cause:

A response from the device included IIN bytes along with the bit set. This indicates that the device requires time synchronization from the master.

Solution:

N/A

Device <device> restarting.

Error Type:

Information

Possible Cause:

The client wrote a "1" to a Warmrestart or Coldrestart tag.

Solution:

N/A

Device <device name> is not responding.

Error Type:

Serious

Possible Cause:

1. The serial connection between the device and the host PC is broken.
2. The communications parameters for the serial connection are incorrect.
3. The named device may have been assigned an incorrect network ID.
4. A device on the channel is unresponsive, due to improper timing settings or a broken communications link.
5. The response from the device took longer to receive than the amount of time specified in the "Request Timeout" device setting.

Solution:

1. Verify the cabling between the DNP master and the DNP slave device.
2. Verify that the specified communications parameters match those of the device.
3. Verify that the network ID given to the named device matches that of the actual device.
4. Locate the unresponsive device and then correct the timing settings or fix the broken communications link.
5. Increase the request timeout so the entire response can be handled.

See Also:

[Timing and Other Considerations Communications](#)

Reached Max. Events Per Point for object group <object group> Point <data index> on device <device>.

Error Type:

Warning

Possible Cause:

At least one unconfirmed event was lost because the event buffers did not have enough room to store the information.

Reasons:

1. The value specified for the Max. Events Per Point parameter is too small to receive all of the events without discarding data.
2. The event poll intervals are too large.
3. The slave is logging unnecessary events (such as changes in a floating value).

Solution:

1. Determine the buffer size allowed in the slave, and then set the Max. Events Per Point parameter to the same value (or larger). This driver allows 10000 events per point. The default setting is 100.
2. If many events occur between event polls (and the Max. Events Per Point is reached) decrease the event poll interval to keep the buffer size small.
3. To avoid logging unnecessary events, adjust the analog point deadband.

See Also:

[Event Playback](#)

Request failed on device <device>. Device does not support the function code (IIN2.0).

Error Type:

Warning

Possible Cause:

The device returned IIN bytes in the response with the "Function code not supported" bit set. This indicates that the device does not support the function code sent by the master in the request.

Solution:

In channel diagnostics, check the TX entry that has a similar timestamp as the error in the Event Log to determine which function code the device is not supporting. The solution depends on the function code.

Note:

For example, if the device should support the "Enable unsolicited responses" (0x14) function code or the "Disable unsolicited responses" (0x15) function code, correct the configuration in the device. If the device should not accept the function codes 0x14 or 0x15, change the Class 1, 2, and 3 Unsolicited Mode in device properties to Automatic. For more information on specific function code error messages, refer to [Error Descriptions](#).

Request to enable unsolicited messaging failed on device <device>.

Error Type:

Warning

Possible Cause:

The device rejected a request to enable unsolicited messages on startup.

1. The device may not be configured to allow the master to modify its unsolicited settings.
2. This is possibly due to an issue with the authentication settings.

Solution:

1. Check how unsolicited or spontaneous messaging is configured in the device. If it does not allow the master to configure unsolicited settings, change the unsolicited modes for each class to Automatic in the master's Unsolicited tab in device properties.
2. Confirm that the authentication settings specified in the master match those specified in the slave.

Unable to bind to local address (IP: xxx.xxx.xxx.xxx, Source Port: x).

Error Type:

Serious

Possible Cause:

1. More than one channel has been configured to use the same network adapter and source port. When Ethernet encapsulation is used on a serial channel, the destination port is also the Source Port to be bound.
2. Another application running on the system has already acquired the indicated network adapter and source port for exclusive use.

Solution:

1. Select a different local IP address or source port for one of the repeating channels. Then confirm that the serial channel utilizing Ethernet encapsulation does not use a destination port that matches an Ethernet channel's source port. The computer may also need to be multi-homed.
2. Close the other application.

Unable to read point(s) <OBJ.VAR.IDX> on device <device>. Failed to initialize communication stack.

Error Type:

Fatal

Possible Cause:

The driver was unable to initialize the communication stack.

Solution:

Reinitialize the driver by right-clicking on the Administration menu and selecting **Reinitialize**. If the problem persists, restart the master.

Unable to read point(s) <OBJ.VAR.IDX> on device <device>. Internal error occurred.

Error Type:

Fatal

Possible Cause:

An internal error occurred within the driver.

Solution:

The driver may recover on its own. If the problem persists, restart the master.

Unable to read point(s) <OBJ.VAR.IDX – OBJ.VAR.IDX> on device <device>. Failed to initialize communication stack.

Error Type:

Fatal

Possible Cause:

The driver was unable to initialize the communication stack.

Solution:

Reinitialize the driver by right-clicking on the Administration menu and selecting **Reinitialize**. If the problem persists, restart the master.

Unable to read point(s) <OBJ.VAR.IDX – OBJ.VAR.IDX> on device <device>. Internal error occurred.

Error Type:

Fatal

Possible Cause:

An internal error occurred within the driver.

Solution:

The driver may recover on its own. If the problem persists, restart the master.

Unable to read tag <tag address> on device <device>. Device indicates one or more exception conditions (DNP flags byte=<hexadecimal byte> - <DNP flag exception list>).

Error Type:

Warning

Possible Cause:

The device returned the data point DNP flag byte with either the Online bit cleared or with one or more of the exception bits set.

Solution:

For a list of flag bits that are specific to the object group, refer to the "DNP Object Flag Definitions" subtopic located in the object group's address descriptions. For more information on a particular exception and how to clear it, refer to the device's documentation.

Unable to receive response from device <device> within timeout. Either the request or response could not be completed or the response is invalid.

Error Type:

Warning

Possible Cause:

1. The Response Timeout is too short to allow the slave's integrity or event poll response to complete in time. The slave may be returning a large number of points, but the timeout elapsed before the data could be received.
2. There is an issue with the authentication settings.
3. The data set exchange objects 213 and 215 are unknown to the device during initialization, causing it to be unable to complete.
4. The connection between the device and the host PC was interrupted while receiving the response.

Solution:

1. If the slave has been configured to return a large number of points (such as during a class 0 poll) change the channel's Response Timeout to a value that allows the response to complete successfully.
2. Confirm that the authentication settings in the master match those in the slave.
3. If data sets are not in use, disable the Exchange Data Sets property in the Advanced tab of device properties.
4. Verify the cabling between the DNP master and the DNP slave device.

Notes:

1. The channel's Response Timeout should be as accurate as possible, because it is also the time that the driver waits before reporting that the device is not responding.
2. The device Request Timeout should be greater than the channel Response Timeout.

See Also:

[Timing and Other Considerations Communications](#)

Unable to write to address <address> on device <device>. Failed to initialize communication stack.

Error Type:

Fatal

Possible Cause:

The driver was unable to initialize the communication stack.

Solution:Reinitialize the driver by right-clicking on the Administration menu and selecting **Reinitialize**. If the problem persists, restart the master.

Unable to write to address <address> on device <device>. Internal error occurred.

Error Type:

Fatal

Possible Cause:

An internal error occurred within the driver.

Solution:

The driver may recover on its own. If the problem persists, restart the master.

Write complete to data set <index> on device <device>.

Error Type:

Informational

Possible Cause:

A data set tag with the subtype .Set had a Boolean True written to it while pending writes existed.

Solution:

The pending data set writes have been sent to the device, although they may not have been successful.

Note:

This message indicates that the write completed and the pending data has been cleared.

DNP Specific Error Messages

The following error/warning messages may be generated. Click on the link for a description of the message.

[Read Errors](#)[Write Errors](#)

Read Errors

The following messages may be generated. Click on the link for a description of the message.

[The returned value for tag address <tag address> in device <device name> has a length of zero.](#)[The tag value cannot be set.](#)[The returned value of <date returned value> for tag address <address> in device <device> is invalid for the <data type> tag data type.](#)[The returned value of <returned numeric value> for tag address <address> in device <device> is invalid for the <data type> tag data type.](#)[The returned value of <returned numeric value> for tag address <address> in device <device> is out of range for the <data type> tag data type.](#)[The returned value of <returned string value> for tag address <address> in device <device> is invalid for the <data type> tag data type.](#)[Unable to read point\(s\) <OBJ.VAR.IDX> on device <device>. An abnormal condition exists in the device \(IIN1.6\).](#)[Unable to read point\(s\) <OBJ.VAR.IDX> on device <device>. Device detected corrupt configuration \(IIN2.5\).](#)

Unable to read point(s) <OBJ.VAR.IDX> on device <device>. Device does not support a point in the range or other parameter error (IIN2.2).

Unable to read point(s) <OBJ.VAR.IDX> on device <device>. Device does not support requested operation for objects in the request (IIN2.1).

Unable to read point(s) <OBJ.VAR.IDX> on device <device>. Device does not support the function code (IIN2.0).

Unable to read point(s) <OBJ.VAR.IDX> on device <device>. Device reports that some output points are in local mode (IIN1.5).

Unable to read point(s) <OBJ.VAR.IDX> on device <device>. Device reports that the operation is already executing (IIN2.4).

Unable to read point(s) <OBJ.VAR.IDX> on device <device>. Session shutting down or duplicate request.

Unable to read point(s) <OBJ.VAR.IDX> on device <device>. Unable to receive response from device <device> within timeout. Either the request or response could not be completed or the response is invalid.

Unable to read point(s) <OBJ.VAR.IDX> on device <device>. Unrecognized object returned in response.

Unable to read point(s) <OBJ.VAR.IDX - OBJ.VAR.IDX> on device <device>. An abnormal condition exists in the device (IIN1.6).

Unable to read point(s) <OBJ.VAR.IDX - OBJ.VAR.IDX> on device <device>. Device detected corrupt configuration (IIN2.5).

Unable to read point(s) <OBJ.VAR.IDX - OBJ.VAR.IDX> on device <device>. Device does not support a point in the range or other parameter error (IIN2.2).

Unable to read point(s) <OBJ.VAR.IDX - OBJ.VAR.IDX> on device <device>. Device does not support requested operation for objects in the request (IIN2.1).

Unable to read point(s) <OBJ.VAR.IDX - OBJ.VAR.IDX> on device <device>. Device does not support the function code (IIN2.0).

Unable to read point(s) <OBJ.VAR.IDX - OBJ.VAR.IDX> on device <device>. Device reports that some output points are in local mode (IIN1.5).

Unable to read point(s) <OBJ.VAR.IDX - OBJ.VAR.IDX> on device <device>. Device reports that the operation is already executing (IIN2.4).

Unable to read point(s) <OBJ.VAR.IDX - OBJ.VAR.IDX> on device <device>. Session shutting down or duplicate request.

Unable to read point(s) <OBJ.VAR.IDX - OBJ.VAR.IDX> on device <device>. Unable to receive response from device <device> within timeout. Either the request or response could not be completed or the response is invalid.

Unable to read point(s) <OBJ.VAR.IDX - OBJ.VAR.IDX> on device <device>. Unrecognized object returned in response.

Unable to read set <set index> of object group <object group> on device <device>. An abnormal condition exists in the device (IIN1.6).

Unable to read set <set index> of object group <object group> on device <device>. Device detected corrupt configuration (IIN2.5).

Unable to read set <set index> of object group <object group> on device <device>. Device does not support a point in the range or other parameter error (IIN2.2).

Unable to read set <set index> of object group <object group> on device <device>. Device does not support requested operation for objects in the request (IIN2.1).

Unable to read set <set index> of object group <object group> on device <device>. Device does not support the function code (IIN2.0).

Unable to read set <set index> of object group <object group> on device <device>. Device reports that some output points are in local mode (IIN1.5).

Unable to read set <set index> of object group <object group> on device <device>. Device reports that the operation is already executing (IIN2.4).

Unable to read set <set index> of object group <object group> on device <device>. Session shutting down or duplicate request.

Unable to read set <set index> of object group <object group> on device <device>. Unrecognized object returned in response.

Unable to read tag address <address> on device <device>. Element index <variation> is not defined in data set <index>.

Unable to read tag address <address> on device <device>. No definition for data set <index>.

Unable to read tag address <address> on device <device>. Response missing data.

The returned value for tag address <tag address> in device <device name> has a length of zero. The tag value cannot be set.

Error Type:

Warning

Possible Cause:

The tag has addressed an element that has been defined in the slave with a data length of zero.

Solution:

Increase the data length to an appropriate value for the data type.

The returned value of <date returned value> for tag address <address> in device <device> is invalid for the <data type> tag data type.

Error Type:

Warning

Possible Cause:

The device has configured the device attribute variation or data set element as a Date value, but the tag's data type is not Date.

Solution:

Change the tag's data type to Date.

The returned value of <returned numeric value> for tag address <address> in device <device> is invalid for the <data type> tag data type.

Error Type:

Warning

Possible Cause:

The device has configured the device attribute variation or data set element as a numeric value, but the tag's data type is String.

Solution:

Change the tag's data type to the appropriate numeric type.

The returned value of <returned numeric value> for tag address <address> in device <device> is out of range for the <data type> tag data type.

Error Type:

Warning

Possible Cause:

The device has configured the device attribute variation or data set element as a data type that is out of range for the data type of the tag.

Solution:

Change the tag's data type to match the data type configured in the slave.

The returned value of <returned string value> for tag address <address> in device <device> is invalid for the <data type> tag data type.

Error Type:

Warning

Possible Cause:

The device has configured the device attribute variation or data set element as a string, but the tag's data type is numeric.

Solution:

Change the tag's data type to String.

Unable to read point(s) <OBJ.VAR.IDX> on device <device>. An abnormal condition exists in the device (IIN1.6).

Error Type:

Warning

Possible Cause:

An abnormal condition has occurred that is specific to the device.

Solution:

Resolve any hardware issues found in the slave.

Unable to read point(s) <OBJ.VAR.IDX> on device <device>. Device detected corrupt configuration (IIN2.5).

Error Type:

Warning

Possible Cause:

The device has detected that its configuration is corrupt.

Solution:

Reconfigure the slave.

Unable to read point(s) <OBJ.VAR.IDX> on device <device>. Device does not support a point in the range or other parameter error (IIN2.2).

Error Type:

Warning

Possible Cause:

1. The device does not support a point in the specified range.
2. The device does not understand the parameters sent in the request.

Solution:

Change the point(s) to one supported by the slave.

Unable to read point(s) <OBJ.VAR.IDX> on device <device>. Device does not support requested operation for objects in the request (IIN2.1).

Error Type:

Warning

Possible Cause:

The device does not support the requested operation for the objects in the request.

Solution:

Verify that the slave supports the requested operation.

Unable to read point(s) <OBJ.VAR.IDX> on device <device>. Device does not support the function code (IIN2.0).

Error Type:

Warning

Possible Cause:

The device does not support the function code.

Solution:

N/A

Note:

For more information, refer to the device's documentation.

Unable to read point(s) <OBJ.VAR.IDX> on device <device>. Device reports that some output points are in local mode (IIN1.5).

Error Type:

Warning

Possible Cause:

Some output points are in local mode.

Solution:

Correct the mode in the slave's configuration.

Note:

For more information, refer to the device's documentation.

Unable to read point(s) <OBJ.VAR.IDX> on device <device>. Device reports that the operation is already executing (IIN2.4).

Error Type:

Warning

Possible Cause:

The specified point is being acted on by another client.

Solution:

1. Stop the other client from acting on the points.
2. Delay the operation of the points.

Unable to read point(s) <OBJ.VAR.IDX> on device <device>. Session shutting down or duplicate request.

Error Type:

Warning

Possible Cause:

The client disconnected while a transaction was in progress.

Solution:

Confirm that the connection between the master and the slave is okay.

Unable to read point(s) <OBJ.VAR.IDX> on device <device>. Unable to receive response from device <device> within timeout. Either the request or response could not be completed or the response is invalid.

Error Type:

Warning

Possible Cause:

1. The Response Timeout is too short to allow the read to complete in time. The slave may have returned a large number of points in the response, but the timeout elapsed before the data was received.
2. There is an issue with the authentication settings.

Solution:

1. If the slave is returning a large number of points in the response, change the Channel Response Timeout to a value that allows the response to complete successfully.

2. Confirm that the authentication settings in the master match those in the slave.

Notes:

1. The Channel Response Timeout should be as accurate as possible, because it is also the time that the driver waits before reporting that the device is not responding.
2. The Device Request Timeout should be greater than the Channel Response Timeout.

See Also:

[Timing and Other Considerations Communications](#)

Unable to read point(s) <OBJ.VAR.IDX> on device <device>. Unrecognized object returned in response.

Error Type:

Warning

Possible Cause:

The response from the slave contains something that is unrecognized. This does not include function codes or objects, which have their own error messages. For more information, refer to the list below.

1. The qualifier may be incorrect or unsupported.
2. The length of the response may not match the length that was expected.
3. For Object Group 87 - Data set reads, this error may mean that more elements are in the data set than are allowed.

Solution:

1. Review the channel diagnostics to find which qualifier is being used in the response from the slave. Then, check the object's implementation table to see if that qualifier is supported. If it is not, determine whether the slave can be configured to use a supported qualifier for the object or function code.
2. Review the channel diagnostics to find if the length reported in the response matches the number of bytes actually sent from the slave, or if the checksum was calculated correctly. Then, determine whether a faulty connection is causing the missing bytes and correct as necessary.
3. If the tag is a data set tag of Object Group 87 and the data set has more than 32 elements, reduce the number of elements in the data set on the slave.

Unable to read point(s) <OBJ.VAR.IDX – OBJ.VAR.IDX> on device <device>. An abnormal condition exists in the device (IIN1.6).

Error Type:

Warning

Possible Cause:

An abnormal condition has occurred that is specific to the device.

Solution:

Resolve any hardware issues found in the slave.

Unable to read point(s) <OBJ.VAR.IDX – OBJ.VAR.IDX> on device <device>. Device detected corrupt configuration (IIN2.5).

Error Type:

Warning

Possible Cause:

The device has detected that its configuration is corrupt.

Solution:

Reconfigure the slave.

**Unable to read point(s) <OBJ.VAR.IDX – OBJ.VAR.IDX> on device <device>.
Device does not support a point in the range or other parameter error (IIN2.2).**

Error Type:

Warning

Possible Cause:

1. The device does not support a point in the specified range.
2. The device does not understand the parameters sent in the request.

Solution:

Change the points to ones supported by the slave.

**Unable to read point(s) <OBJ.VAR.IDX – OBJ.VAR.IDX> on device <device>.
Device does not support requested operation for objects in the request
(IIN2.1).**

Error Type:

Warning

Possible Cause:

The device does not support the requested operation for the objects in the request.

Solution:

Verify that the slave supports the requested operation.

**Unable to read point(s) <OBJ.VAR.IDX – OBJ.VAR.IDX> on device <device>.
Device does not support the function code (IIN2.0).**

Error Type:

Warning

Possible Cause:

The device does not support the function code.

Solution:

N/A

Note:

For more information, refer to the device's documentation.

**Unable to read point(s) <OBJ.VAR.IDX – OBJ.VAR.IDX> on device <device>.
Device reports that some output points are in local mode (IIN1.5).**

Error Type:

Warning

Possible Cause:

Some output points are in local mode.

Solution:

Correct the mode in the slave's configuration.

Note:

For more information, refer to the device's documentation.

**Unable to read point(s) <OBJ.VAR.IDX – OBJ.VAR.IDX> on device <device>.
Device reports that the operation is already executing (IIN2.4).**

Error Type:

Warning

Possible Cause:

The specified points are being acted on by another client.

Solution:

1. Stop the other client from acting on the points.
2. Delay the operation of the points.

Unable to read point(s) <OBJ.VAR.IDX – OBJ.VAR.IDX> on device <device>. Session shutting down or duplicate request.

Error Type:

Warning

Possible Cause:

The client disconnected while a transaction was in progress.

Solution:

Confirm that the connection between the master and the slave is okay.

Unable to read point(s) <OBJ.VAR.IDX - OBJ.VAR.IDX> on device <device>. Unable to receive response from device <device> within timeout. Either the request or response could not be completed or the response is invalid.

Error Type:

Warning

Possible Cause:

1. The Response Timeout is too short to allow the read to complete in time. The slave may have returned a large number of points in the response, but the timeout elapsed before the data was received.
2. There is an issue with the authentication settings.

Solution:

1. If the slave is returning a large number of points in the response, change the Channel Response Timeout to a value that allows the response to complete successfully.
2. Confirm that the authentication settings in the master match those in the slave.

Notes:

1. The Channel Response Timeout should be as accurate as possible, because it is also the time that the driver waits before reporting that the device is not responding.
2. The Device Request Timeout should be greater than the Channel Response Timeout.

See Also:

[Timing and Other Considerations Communications](#)

Unable to read point(s) <OBJ.VAR.IDX – OBJ.VAR.IDX> on device <device>. Unrecognized object returned in response.

Error Type:

Warning

Possible Cause:

The slave does not support the read request.

Solution:

Change the request to one supported by the slave.

Unable to read set <set index> of object group <object group> on device <device>. An abnormal condition exists in the device (IIN1.6).

Error Type:

Warning

Possible Cause:

An abnormal condition has occurred that is specific to the device.

Solution:

Resolve any hardware issues found in the slave.

Unable to read set <set index> of object group <object group> on device <device>. Device detected corrupt configuration (IIN2.5).

Error Type:

Warning

Possible Cause:

The device has detected that its configuration is corrupt.

Solution:

Reconfigure the slave.

Unable to read set <set index> of object group <object group> on device <device>. Device does not support a point in the range or other parameter error (IIN2.2).

Error Type:

Warning

Possible Cause:

1. The device does not support a point in the specified range.
2. The device does not understand the parameters sent in the request.

Solution:

Change the points to one supported by the slave.

Unable to read set <set index> of object group <object group> on device <device>. Device does not support requested operation for objects in the request (IIN2.1).

Error Type:

Warning

Possible Cause:

The device does not support the requested operation for the objects in the request.

Solution:

Verify that the slave supports the requested operation.

Unable to read set <set index> of object group <object group> on device <device>. Device does not support the function code (IIN2.0).

Error Type:

Warning

Possible Cause:

The device does not support the function code.

Solution:

N/A

Note:

For more information, refer to the device's documentation.

Unable to read set <set index> of object group <object group> on device <device>. Device reports that some output points are in local mode (IIN1.5).

Error Type:

Warning

Possible Cause:

Some output points are in local mode.

Solution:

Correct the mode in the slave's configuration.

Note:

For more information, refer to the device's documentation.

Unable to read set <set index> of object group <object group> on device <device>. Device reports that the operation is already executing (IIN2.4).

Error Type:

Warning

Possible Cause:

The specified point is being acted on by another client.

Solution:

1. Stop the other client from acting on the points.
2. Delay the operation of the points.

Unable to read set <set index> of object group <object group> on device <device>. Session shutting down or duplicate request.

Error Type:

Warning

Possible Cause:

The client disconnected while a transaction was in progress.

Solution:

Confirm that the connection between the master and the slave is okay.

Unable to read set <set index> of object group <object group> on device <device>. Unrecognized object returned in response.

Error Type:

Warning

Possible Cause:

The response from the slave contains something that is unrecognized. This does not include function codes or objects, which have their own error messages. For more information, refer to the list below.

1. The qualifier may be incorrect or unsupported.
2. The length of the response may not match the length that was expected.

3. For Object Group 87 - Data set reads, this error may mean that more elements are in the data set than are allowed.

Solution:

1. Review the channel diagnostics to find which qualifier is being used in the response from the slave. Then, check the object's implementation table to see if that qualifier is supported. If it is not, determine whether the slave can be configured to use a supported qualifier for the object or function code.
2. Review the channel diagnostics to find if the length reported in the response matches the number of bytes actually sent from the slave, or if the checksum was calculated correctly. Then, determine whether a faulty connection is causing the missing bytes and correct as necessary.
3. If the tag is a data set tag of Object Group 87 and the data set has more than 32 elements, reduce the number of elements in the data set on the slave.

Unable to read tag address <address> on device <device>. Element index <variation> is not defined in data set <index>.

Error Type:

Warning

Possible Cause:

The slave does not define this element index within the data set.

Solution:

1. If the element index should be defined, correct the data set in the slave.
2. If the element index is invalid, correct the tag address in the project.

Unable to read tag address <address> on device <device>. No definition for data set <index>.

Error Type:

Warning

Possible Cause:

1. A data set definition does not exist for the data set index of the .Value tag being read.
2. A data set exchange took place between the master and the slave. A new data set was then added in the slave unknown to the master.

Solution:

1. Create the data set in the slave.
2. Initiate a data set exchange. To do so, click **Device Properties | Tag Import** and then select **Import Tags**. Alternatively, restart the master.

Unable to read tag address <address> on device <device>. Response missing data.

Error Type:

Warning

Possible Cause:

Although the response from the slave indicated success, data for one or more points in the requested range was not included in the response.

Solution:

Confirm that the points are enabled in the slave.

Note:

For example, if the tag references Object Group 87 - Data sets, confirm that all data set elements are configured in the slave with the correct data type and length and that the data set characteristics are correctly configured.

Write Errors

The following messages may be generated. Click on the link for a description of the message.

[Unable to write to address <address> on device <device>. Activate Configuration-Related Status Code <status code> - <description>.](#)

[Unable to write to address <address> on device <device>. An abnormal condition exists in the device \(IIN1.6\).](#)

[Unable to write to address <address> on device <device>. Channel response Timeout must be between <min. channel response timeout> and <max. channel response timeout>.](#)

[Unable to write to address <address> on device <device>. Control-Related Status Code <status code>.](#)

[Unable to write to address <address> on device <device>. Device detected corrupt configuration \(IIN2.5\).](#)

[Unable to write to address <address> on device <device>. Device does not support a point in the range or other parameter error \(IIN2.2\).](#)

[Unable to write to address <address> on device <device>. Device does not support requested operation for objects in the request \(IIN2.1\).](#)

[Unable to write to address <address> on device <device>. Device does not support the function code \(IIN2.0\).](#)

[Unable to write to address <address> on device <device>. Device reports that some output points are in local mode \(IIN1.5\).](#)

[Unable to write to address <address> on device <device>. Device reports that the operation is already executing \(IIN2.4\).](#)

[Unable to write to address <address> on device <device>. Device Request Timeout must be between <min. value> and <max. value>.](#)

[Unable to write to address <address> on device <device>. Element index <variation> is not defined in data set <index>.](#)

[Unable to write to address <address> on device <device>. Event Poll Interval must be between <min. value> and <max. value>.](#)

[Unable to write to address <address> on device <device>. File name writes have been disabled.](#)

[Unable to write to address <address> on device <device>. Integrity Poll Interval must be between <min. value> and <max. value>.](#)

[Unable to write to address <address> on device <device>. Master address <master address> already in use as slave address on device <device>.](#)

[Unable to write to address <address> on device <device>. Master address must be between <min. master address> and <max. master address>.](#)

[Unable to write to address <address> on device <device>. Master and slave address cannot be the same.](#)

[Unable to write to address <address> on device <device>. No definition for data set <index>.](#)

[Unable to write to address <address> on device <device>. Select operate response invalid.](#)

[Unable to write to address <address> on device <device>. Session shutting down or duplicate request.](#)

[Unable to write to address <address> on device <device>. Slave address <slave address> already in use on device <device>.](#)

[Unable to write to address <address> on device <device>. Slave address must be between <min. slave address> and <max. slave address>.](#)

[Unable to write to address <address> on device <device>. Tag <data type> data type is incompatible with the data set element <data type> data type.](#)

[Unable to write to address <address> on device <device>. Unable to receive response from device <device> within timeout. Either the request or response could not be completed or the response is invalid.](#)

[Unable to write to address <address> on device <device>. Unrecognized object returned in response.](#)

[Unable to write to address <address> on device <device>. Unsupported operation type.](#)

[Unable to write to address <address> on device <device>. Unsupported Trip-Close Code.](#)

[Unable to write to address <address> on device <device>. Write value specified is invalid or incomplete.](#)

Unable to write to address <address> on device <device>. Activate Configuration-Related Status Code <status code> - <description>.

Error Type:

Warning

Possible Cause:

The Activate Configuration Request that was sent to the slave contained an invalid object or specification string.

Solution:

For information on a specific status code, refer to the table below.

Status Code	Description
0	No errors were detected in the corresponding request object. No errors were detected in the configuration data referenced by the corresponding request object.
1	An error was detected in the request object. For example, the slave was unable to locate a file referenced by a g70 file specification string, or the slave does not have a name referenced by a g110 octet string.
2	An error was detected in the configuration data referenced by the corresponding request data.
3	An error occurred that is not listed above.
4	The Activate Config Object was not checked for errors.

Unable to write to address <address> on device <device>. An abnormal condition exists in the device (IIN1.6).

Error Type:

Warning

Possible Cause:

An abnormal condition has occurred that is specific to the device.

Solution:

Resolve any hardware issues found in the slave.

Unable to write to address <address> on device <device>. Channel Response Timeout must be between <min. channel response timeout> and <max. channel response timeout>.

Error Type:

Warning

Possible Cause:

The value is out of range.

Solution:

Specify a value within the Channel Response Timeout range of 100 to 3600000 milliseconds.

Unable to write to address <address> on device <device>. Control-Related Status Code <status code>.

Error Type:

Warning

Possible Cause:

1. The value written to the .Operate sub-type was not understood by the DNP slave.
2. If the operate was successful but the feedback poll failed, the device reports status code 4.

Solution:

For information on a specific code number, refer to the table below.

Code Number	Identifier Name	Description
0	Success	Request accepted, initiated, or queued.
1	Timeout	Request not accepted because the operate message was received after the arm timer timed out. The arm timer was started when the select operation for the same point was received.
2	No_Select	Request not accepted because no previous matching select request exists. An operate message was sent to activate an output that was not previously armed with a matching select message.
3	Format_Error	Request not accepted because there were formatting errors in the control request (either select, operate, or direct operate).
4	Not_Supported	<ol style="list-style-type: none"> 1. Request not accepted because a control operation is not supported for this point. 2. The device does not understand the feedback poll request for the latest value of all objects of an object group.
5	Already_Active	Request not accepted because the control queue is full (or the point is already active).
6	Hardware_Error	Request not accepted because of control hardware problems.
7	Local	Request not accepted because the local/remote switch is in the local position.
8	Too_Many_Objs	Request not accepted because too many objects appeared in the same request.
9	Not_Authorized	Request not accepted because of insufficient authorization.
10	Automation_Inhibit	Request not accepted because it was prevented or inhibited by a local automation process.
11	Processing_Limited	Request not accepted because the device cannot process any more activities than are presently in progress.
12	Out_Of_Range	Request not accepted because the value is outside the acceptable range permitted for this point.
13 to 125	Reserved	Reserved for future use.
126	Non_Participating	Sent in request messages indicating that the outstation neither issued nor performed the control operation.
127	Undefined	Request not accepted due to an undefined reason.

Unable to write to address <address> on device <device>. Device detected corrupt configuration (IIN2.5).

Error Type:

Warning

Possible Cause:

The device has detected that its configuration is corrupt.

Solution:

Reconfigure the slave.

Unable to write to address <address> on device <device>. Device does not support a point in the range or other parameter error (IIN2.2).

Error Type:

Warning

Possible Cause:

1. The device does not support a point in the specified range.
2. The device does not understand the parameters sent in the request.

Solution:

Change the tag address to one supported by the slave.

Unable to write to address <address> on device <device>. Device does not support requested operation for objects in the request (IIN2.1).

Error Type:

Warning

Possible Cause:

The device does not support the requested operation for the objects in the request.

Solution:

Verify that the slave supports the requested operation.

Unable to write to address <address> on device <device>. Device does not support the function code (IIN2.0).

Error Type:

Warning

Possible Cause:

The device does not support the function code.

Solution:

N/A

Note:

For more information, refer to the device's documentation.

Unable to write to address <address> on device <device>. Device reports that some output points are in local mode (IIN1.5).

Error Type:

Warning

Possible Cause:

Some output points are in local mode.

Solution:

Correct the mode in the slave's configuration.

Note:

For more information, refer to the device's documentation.

Unable to write to address <address> on device <device>. Device reports that the operation is already executing (IIN2.4).

Error Type:

Warning

Possible Cause:

The specified address is being acted on by another client.

Solution:

1. Stop the other client from acting on the address.
2. Delay the operation of the address.

Unable to write to address <address> on device <device>. Device Request Timeout must be between <min. value> and <max. value>.

Error Type:

Warning

Possible Cause:

The value is out of range.

Solution:

Specify a value within the device Request Timeout range of 0 to 3600000 seconds.

Unable to write to address <address> on device <device>. Element index <variation> is not defined in data set <index>.

Error Type:

Warning

Possible Cause:

The slave does not define this element index within the data set.

Solution:

1. If the element index should be defined, correct the data set in the slave.
2. If the element index is invalid, correct the tag address in the project.

Unable to write to address <address> on device <device>. Event Poll Interval must be between <min. value> and <max. value>.

Error Type:

Warning

Possible Cause:

The value is out of range.

Solution:

Specify a value within the Event Poll Interval range of 0 to 86400 seconds.

Unable to write to address <address> on device <device>. File name writes have been disabled.

Error Type:

Warning

Possible Cause:

An attempt to modify the value of a 70.<index>.LocalFileName tag or 70.<index>.RemoteFileName tag failed because the enable file name writes parameter was disabled in File Control (located in device properties).

Solution:

Change the enable file name writes parameter to "Yes".

See Also:

[File Control](#)

Unable to write to address <address> on device <device>. Integrity Poll Interval must be between <min. value> and <max. value>.

Error Type:

Warning

Possible Cause:

The value is out of range.

Solution:

Specify a value within the Integrity Poll Interval range of 0 to 2592000 seconds.

Unable to write to address <address> on device <device>. Master address <master address> already in use as slave address on device <device>.

Error Type:

Warning

Possible Cause:

The master address is already in use as a slave address on another device.

Solution:

Specify a master address that is unique among all slave addresses in the channel.

Unable to write to address <address> on device <device>. Master address must be between <min. master address> and <max. master address>.

Error Type:

Warning

Possible Cause:

The value is out of range.

Solution:

Specify a value within the master address range of 0 to 65519.

Unable to write to address <address> on device <device>. Master and slave address cannot be the same.

Error Type:

Warning

Possible Cause:

The master address and slave address are the same.

Solution:

Specify unique values for the master address and the slave address.

Unable to write to address <address> on device <device>. No definition for data set <index>.

Error Type:

Warning

Possible Cause:

1. A data set definition does not exist for the data set index of the write tag.
2. A data set exchange took place between the master and the slave. A new data set was then added in the slave unknown to the master.

Solution:

1. Create the data set in the slave.
2. Initiate a data set exchange. To do so, click **Device Properties | Tag Import** and then select **Import Tags**. Alternatively, restart the master.

Unable to write to address <address> on device <device>. Select operate response invalid.

Error Type:

Warning

Possible Cause:

The device did not return an acceptable response to a Select then operate request.

Solution:

Verify that the slave is configured to operate on the point.

Unable to write to address <address> on device <device>. Session shutting down or duplicate request.

Error Type:

Warning

Possible Cause:

The client disconnected while a transaction was in progress.

Solution:

Confirm that the connection between the master and the slave is okay.

Unable to write to address <address> on device <device>. Slave address <slave address> already in use on device <device>.

Error Type:

Warning

Possible Cause:

The slave address is already in use as a master address or slave address on another device in the channel.

Solution:

Specify a slave address that is unique among all master addresses and slave addresses in the channel.

Unable to write to address <address> on device <device>. Slave address must be between <min. slave address> and <max. slave address>.

Error Type:

Warning

Possible Cause:

The value is out of range.

Solution:

Specify a value within the slave address range of 0 to 65519.

Unable to write to address <address> on device <device>. Tag <data type> data type is incompatible with the data set element <data type> data type.

Error Type:

Warning

Possible Cause:

1. The value being written is incompatible with the definition of the data set for that element.
2. The value being written is less than the minimum value or greater than the maximum value that is allowed for the data type. This error may also be caused by a value of \pm infinity to \pm NaN.

Solution:

1. Correct the tag's data type so that it matches the data type defined for the element in the data set.
2. Write a value that is within the valid range allowed for the data type.

Unable to write to address <address> on device <device>. Unable to receive response from device <device> within timeout. Either the request or response could not be completed or the response is invalid.

Error Type:

Warning

Possible Cause:

1. The Response Timeout is too short to allow the write to complete in time. The slave may have returned a large number of points in the feedback poll, but the timeout elapsed before the data was received.
2. There is an issue with the authentication settings.

Solution:

1. If the slave is returning a large number of points in the feedback poll, change the channel's Response Timeout to a value that allows the response to complete successfully.
2. Confirm that the authentication settings in the master match those in the slave.

Notes:

1. The channel's Response Timeout should be as accurate as possible, because it is also the time that the driver waits before reporting that the device is not responding.
2. The device's Request Timeout should be greater than the channel's Response Timeout.

See Also:

[Timing and Other Considerations Communications](#)

Unable to write to address <address> on device <device>. Unrecognized object returned in response.

Error Type:

Warning

Possible Cause:

The slave does not support the value being written to the object group.

Solution:

Change the value to one supported by the slave.

Unable to write to address <address> on device <device>. Unsupported operation type.

Error Type:

Fatal

Possible Cause:

An invalid DNP operation code was specified when writing to the .Operate.OpType tag.

Solution:

Correct the .Operate.OpType tag's value.

Unable to write to address <address> on device <device>. Unsupported Trip-Close Code.

Error Type:

Fatal

Possible Cause:

An invalid DNP Trip-Close code was specified when writing to the .Operate.TripCloseCode tag.

Solution:

Correct the .Operate.TripCloseCode tag's value.

Unable to write to address <address> on device <device>. Write value specified is invalid or incomplete.

Error Type:

Warning

Possible Cause:

1. An invalid value was written to the Operate.Set, Operate, Object Group 60, Warmrestart, Coldrestart, ActivateConfig, or data set .Set tag.
2. An attempt to write a data set occurred when there was no pending data to be written.
3. An attempt to write a large data set caused the request message to surpass the maximum fragment size.
4. An attempt to send an Activate Configuration Request failed due to a syntax error.
5. An attempt to send an Activate Configuration Request failed due to a remote file identifier not defined at the 70.index.
6. An attempt to send an Activate Configuration Request failed due to a string not defined at 110.index.
7. An attempt to initiate a file transfer failed because a file transfer is already in progress on that device.

Solution:

1. Correct the value written to the Operate.Set, Operate, Object Group 60, Warmrestart, Coldrestart, or data set .Set tag.
2. Before writing a True to the data set .Set tag, write data to one or more elements of a data set.
3. Reduce the number of bytes being written to the data set.
4. Correct the Activate Config Objects string to a valid format: object.index, object.index, object.index, and so forth.
5. Fix the Activate Config Objects string file object 70.index if it is incorrect. If it is correct, then define the remote file and path at that index.
6. Fix the Activate Config Objects string object 110.index if it is incorrect. If it is correct, then create a tag with the address to that string index.
7. Wait for the file transfer in progress to complete before attempting another on the device.

Note:

The default maximum master transmit fragment size is 2048 bytes.

File Control Messages

The following messages may be generated. Click on the link for a description of the message.

[File transfer failure on device <device> for file index <index>. Device returned File-Related Status Code <status code> - <description>.](#)

[File transfer failure on device <device> for file index <index>. File size of <size> kilobytes is greater than maximum file size of <maximum size> kilobytes.](#)

[File transfer failure on device <device> for file index <index>. File transfer aborted by user.](#)

[File transfer failure on device <device> for file index <index>. File transfer aborted due to communications issue.](#)

[File transfer failure on device <device> for file index <index>. Local file <file name> is empty.](#)

[File transfer failure on device <device> for file index <index>. Local file open failure. <local file open failure>.](#)

[File transfer failure on device <device> for file index <index>. Session shutting down or duplicate request.](#)

[Invalid local file for File Index 70.<file index>, general error.](#)

[Invalid local file for File Index 70.<file index>, verify the specified path is write-enabled.](#)

[Invalid local file path for File Index 70.<file index>.](#)

[Invalid local file syntax for File Index 70.<file index>.](#)

File transfer failure on device <device> for file index <index>. Device returned file-related status code <status code> - <description>.

Error Type:

Warning

Possible Cause:

The slave is reporting that an error occurred during a file transfer request from the master.

Solution:

For information on a specific code number, refer to the table below.

Code Number	Identifier Name	Description
0	Success	The requested operation was successful.
1	Permission_Denied	Permission was denied due to improper authentication key, user name, or password.
2	Invalid_Mode	An unsupported or unknown operation mode was requested.
3	File_Not_Found	The requested file does not exist. The path may be incorrect.
4	File_Locked	The requested file is already in use by another user.
5	Too_Many_Open	File could not be opened because the number of simultaneously opened files would be exceeded.
6	Invalid_Handle	There is no file opened with the handle in the request.
7	Write_Block_Size	The outstation is unable to negotiate a suitable write block size.
8	Comm_Lost	Communications were lost or cannot be established with the end device where the file resides.
9	Cannot_Abort	An abort request was unsuccessful because the slave is unable or not programmed to abort, or the slave knows that aborting the file would make it unusable.
10-15	Reserved	Reserved for future use.
16	Not_Opened	File handle does not reference an opened file.
17	Handle_Expired	File closed due to inactivity timeout. This code is sent in a file transport status event object (g70v6) when the timeout occurs.
18	Buffer_Overrun	Too much file data was received for the slave to process.
19	Fatal	An error happened in the file processing that prevents any further activity with this file.
20	Block_Seq	The block number did not have the expected sequence number.
21-254	Reserved	Reserved for future use.
255	Undefined	Some other error not listed above occurred.

File transfer failure on device <device> for file index <index>. File size of <size> kilobytes is greater than maximum file size of <maximum size> kilobytes.

Error Type:

Warning

Possible Cause:

The file to be copied has a file size that exceeds the configured maximum file size for this file index.

Solution:

If the file size is expected, increase the maximum file size configured for that file index. If the file should not reach that size, determine the reason for its growth.

File transfer failure on device <device> for file index <index>. File transfer aborted by user.

Error Type:

Warning

Possible Cause:

During a file transfer, the user wrote a 0 to the Upload or Download tag of the file index to stop the transfer.

Solution:

N/A

File transfer failure on device <device> for file index <index>. File transfer aborted due to communications issue.

Error Type:

Warning

Possible Cause:

The serial connection between the device and the host PC disconnected during a file transfer.

Solution:

Verify the cabling between the DNP master and the DNP slave device.

File transfer failure on device <device> for file index <index>. Local file <file name> is empty.

Error Type:

Warning

Possible Cause:

The file that is to be downloaded to the slave is empty.

Solution:

Determine why the file is empty. Then, correct it and re-attempt to download the file to the slave.

File transfer failure on device <device> for file index <index>. Local file open failure. <local file open failure>.

Error Type:

Warning

Possible Cause:

1. File was not found.
2. Invalid or incorrect path.
3. Too many open files.
4. Access denied.
5. Disk is full.
6. An unspecified error occurred.

Solution:

1. If the Append option is desired, confirm that the file name and path are configured correctly. Otherwise, change the local file's Open Mode to Overwrite to create a new local file.
2. If the local path is invalid, correct it for the file index in File Control (located in device properties). If the path is incorrect (and the server_runtime is running as a service), then configure the server_runtime service with a non-system user account with the correct permissions.
3. The number of open files exceeds the maximum allowed. Determine what is causing the files to remain open.
4. The file could not be accessed. Correct the file's access rights.
5. The local disk is full. Free up some disk space.
6. Determine the problem with the file or path name.

File transfer failure on device <device> for file index <index>. Session shutting down or duplicate request.

Error Type:

Warning

Possible Cause:

The device disconnected while a transaction was in progress.

Solution:

Confirm that the connection between the master and the slave is okay.

Invalid local file for file Index 70.<file index>, general error.

Error Type:

Warning

Possible Cause:

The specified local file identifier is invalid. The error is unspecified.

Solution:

1. Specify a new local file path and/or name with read/write privileges.
2. If this is a network drive, verify that both the current user and the user associated with the service have read/write privileges.

Invalid local file for File Index 70.<file index>, verify the specified path is write-enabled.

Error Type:

Warning

Possible Cause:

The current user does not have read/write privileges to the specified local file identifier.

Solution:

Verify that the current user (or the user associated with the service) has read/write privileges to the specified file and folders.

Invalid local file path for File Index 70.<file index>.

Error Type:

Warning

Possible Cause:

The local file identifier (which consists of the local file path and Name) does not include a valid path to the file.

Solution:

Verify the file name's directory/folder hierarchy. The specified file is created at run time (excluding its path) if it does not already exist.

Invalid local file syntax for File Index 70.<file index>.

Error Type:

Warning

Possible Cause:

1. The local file identifier (which consists of the local file path and Name) contains one or more invalid characters (such as |?"*:<>).
2. The local file identifier contains the parent directory (denoted by '..'), which is not permitted for security purposes.

Solution:

1. Verify that the specified local file identifier does not contain invalid characters.
2. Verify that the specified local file identifier does not contain the parent directory.

Device Profile

For more information on a specific section of the device profile, select a link from the list below.

[Device Identification](#)

[Link Layer](#)

[Application Layer](#)

[Masters Only](#)

[Security Parameters](#)

[Implementation Tables](#)

Note: For a device profile template, refer to DNP.org.

Device Identification

Component	Description	Current Value	Methods
Device Function	Masters send DNP requests.	Master	N/A
Device Name	This is the model and name of the device, which should distinguish it from any other device from the same organization.	DNP3 Master Serial	N/A
Hardware Version	N/A	- Windows 7 - Windows Server 2008 - Windows Vista Business / Ultimate - Windows Server 2003 SP2 - Windows XP SP2	N/A
Software Version	N/A	v.5	N/A
Device Profile Document Version	The version of the device profile document is indicated by a whole number incremented with each new release.	4	N/A
Supported WITS Major Version	The major version of the WITS Standard implemented by the device.	1	N/A
Supported WITS Minor Version	The minor version of the WITS Standard implemented by the device.	0	N/A
DNP Levels Supported for Requests	The DNP3 level to which the device conforms fully. Requests can be indicated independently.	3	N/A
DNP Levels Supported for responses	The DNP3 level to which the device conforms fully. Responses can be indicated independently.	3	N/A
Supported Function Blocks	N/A	Object 0 - Attribute Objects, Data Sets, File Transfer, Secure Authentication, and Function Code 31 - Activate Configuration.	N/A
Notable Additions	This brief description intends to identify the most obvious features that the device supports, in addition to the highest supported level of DNP. The complete list of features is described in the Implementation Table.	- Enabling and disabling unsolicited responses on an individual class basis. - Double-Bit Input Objects. - Variations with time for Frozen Counters, Frozen Counter Events, and Analog Input Events. - Floating-point variations for both Analog Inputs and	<i>For more information, refer to Address Descriptions.</i>

Component	Description	Current Value	Methods
		Analog Outputs. - Analog Input Reporting Deadband. - Event Objects for Binary and Analog Outputs. - Device attribute objects, including the Standard DNP set 0 and user-defined sets. - Data Set Objects. - Authentication. - File Control. - Activate Configuration.	
Methods to Set Configurable Parameters	N/A	N/A	Methods include .opf and .xml project files.*

*In addition to custom Channel Properties and Device Properties dialogs.

Serial Connections

Component	Description	Current Value	Methods
Serial Port Name	This is the name used to reference the communication port defined in this section.	COM1	The property located on Channel Communications Property page. Ranges from COM1 to COM255.
Serial Connection Parameters	N/A	Data Bits - 8 Stop Bits - 1 Parity - None	Properties located on Channel Communications Property page. Supported parameters are as follows: Data Bits: 5, 6, 7, or 8. Stop Bits: 1 or 2. Parity: None, Even, Odd.
Serial Baud Rate	N/A	9600	Property located on Channel Communications Property page.*
Serial Hardware Flow Control	This parameter describes the interface's hardware signaling requirements. If a transmitter or receiver is inhibited until a given control signal is asserted, it is considered to require that signal prior to sending or receiving characters. If a signal is asserted prior to transmitting, that signal is maintained actively until after the end of transmission. If a signal is asserted to enable reception, any data sent to the device when the signal is not active can be discarded.	N/A	Property located on Channel Communications Property page. Supported flow controls are as follows: - DTR - RTS - RTS-DTR - RTS Always

*Supported baud rates are as follows: 300, 600, 1200, 2400, 9600, 19200, 28800, 38400, 56000, 57600, 115200, 128000, and 256000.

**If no asynchronous serial interface is fitted, this parameter is not applicable. Furthermore, none of the options are selected.

Link Layer

Component	Description	Current Value	Methods
Data Link Address	This indicates if the link address is configurable over the entire valid range of 0 to 65519.	Range: 0 to 65519	Slave Address property located on Device Communications Property page
Sends Confirmed User Data Frames	This is a list of conditions under which the device transmits the following confirmed link layer services: TEST_LINK_STATES RESET_LINK_STATES CONFIRMED_USER_DATA	Never	N/A
Data Link Layer Confirmation Timeout	This timeout applies to any secondary data link message that requires a confirmation or response (such as link reset, link status, user data, and so forth).	2 seconds	N/A
Maximum Data Link Retries	This is the number of times that the device re-transmits a frame that requests Link Layer confirmation.	3 retries	N/A
Maximum Number of Octets Transmitted in a Data Link Frame	This number includes the checksum. With a length field of 255, the maximum size would be 292.	292	N/A
Maximum Number of Octets that can be Received in a Data Link Frame	This number includes the checksum. With a length field of 255, the maximum size would be 292. The device must be able to receive 292 octets to be compliant.	292	N/A

*Data link addresses 0xFFFF0 through 0xFFFF are reserved for broadcast or other special purposes.

Application Layer

Component	Description	Current Value	Methods
Maximum Number of Octets Transmitted in an Application Layer Fragment other than File Transfer	This size does not include any transport or frame octets. Masters must provide a setting less than or equal to 249.	249	N/A
Maximum Number of Octets Transmitted in an Application Layer Fragment Containing File Transfer	N/A	N/A	N/A
Maximum Number of Octets that can be Received in an Application Layer Fragment	This size does not include any transport or frame octets. Masters must provide a setting greater than or equal to 2048.	2048	N/A
Timeout waiting for Complete Application Layer Fragment	Timeout if all frames of a message fragment are not received in the specified time. It is measured from the time that the first frame of a fragment is received until the last frame is received.	N/A	N/A
Maximum Number of objects Allowed in a Single Control Request for CROB (g12)	N/A	N/A	N/A
Maximum Number of	N/A	N/A	N/A

Component	Description	Current Value	Methods
objects Allowed in a Single Control Request for Analog Outputs (g41)			
Maximum Number of objects Allowed in a Single Control Request for data sets (g85, 86, 87)	N/A	N/A	N/A
Supports Mixing object groups* in the Same Control Request	N/A	N/A	N/A

*AOBs, cROBs, and data sets.

Masters Only

Component	Description	Current Value	Methods
Timeout Waiting for Complete Application Layer Response	Timeout on master if all fragments of a response message are not received in the specified time.	10000 ms	Property located on the Channel Communications Property page. Supported response timeouts are 100 to 3600000.
Maximum Application Layer Retries for Request Messages	This is the number of times a master re-transmits an application layer request message if a response is not received. This parameter must never cause a master to retransmit control or time synchronization messages.	0	Max. Timeouts property is located on the Device Communications Property page. Supported timeouts are 1 to 10 (0 to 9 retries).
Incremental Timeout Waiting for First or Next Fragment of an Application Layer Response	N/A	N/A	N/A

Security Parameters

Component	Description	Current Value	Methods
DNP3 Device Support for Secure authentication	Indicates whether the device supports secure authentication (and, if so, what version).	Version 2	Authentication can be enabled on the Authentication tab in device properties. The User Number and Update Key tag properties can be configured in the User Numbers/Update Key tab in device properties.
Maximum Number of Users	The device must support details for each user. Users are identified by a 16-bit user number. Indicates the actual limit to the number of simultaneous users that can be supported.	10	The maximum number of users cannot be configured, but the User Number and Update Keys can be configured in device properties.
Security Message Response Timeout	The authentication of critical messages may involve additional message exchanges (challenges and responses), which can require an	2000 milliseconds	The Reply Timeout property is located on the Authentication tab in device properties. The

Component	Description	Current Value	Methods
	extension to the normal DNP3 message response timeout. This timeout specifies an additional amount of time to be used when extra security transactions are involved.		valid range is 0 to 300000 milliseconds.
Aggressive Mode of Operation (Receive)	DNP3 devices have the option to accept "aggressive" mode requests, where challenge data used for authentication is appended to a critical message instead of being solicited through a separate message exchange.	Yes. Accepts aggressive mode requests	The Enable Aggressive Mode Support property is located on the Authentication tab in device properties.
Aggressive Mode of Operation (Issue)	DNP3 devices must support the issuing of "aggressive" mode of operation, where challenge data used for authentication is appended to a critical message instead of being solicited through a separate message exchange.	Yes. Issues aggressive mode requests	When authentication is enabled, Aggressive Mode Support is enabled by default.
Session Key Change Interval	To defend against a compromising attack, the session key is changed at regular intervals. To accommodate systems with infrequent communications, this change interval can be disabled to use just the Session Key Change Message Count instead.	900 seconds	This property is located on the Authentication tab in device properties. The valid range is 0 to 7200 seconds. 0 disables the interval and uses the Session Key Change Message Count instead.
Session Key Change Message Count	In addition to changing at regular intervals, the session key is also changed after a specified number of messages have been exchanged.	1000	The Session Key Change Count property is located on the Authentication tab in device properties. The valid range is 0 to 65535.
Maximum Error Count	To assist in countering denial of service attacks, the DNP3 device stops replying with error codes after a number of successive authentication failures. Setting the error count to zero inhibits all error messages.	2	This property is located on the Authentication tab in device properties. The valid range is 0 to 10.
MAC Algorithm Requested in Challenge Exchange	Part of the authentication message is hashed using a MAC algorithm. The output of the MAC algorithm is truncated.	Supports the following: HMAC-SHA-1: Truncated to the leftmost 4 octets. HMAC-SHA-1: Truncated to the leftmost 8 octets. HMAC-SHA-1: Truncated to the leftmost 10 octets. HMAC-SHA-256: Truncated to the leftmost 8 octets. HMAC-SHA-256: Truncated to the leftmost 16 octets.	N/A
Key-Wrap	When a session key is updated, it is	Supports AES-128	Not configurable

Component	Description	Current Value	Methods
Algorithm to Encrypt Session Keys	encrypted using AES-128. Other algorithms are optional.		

Implementation Tables

The following implementation tables identify which object groups and variations, function codes, and qualifiers are supported by the master in both requests and responses. The Request columns identify all requests that may be sent by the master, or all requests that must be parsed by a slave. The Response columns identify all responses that must be parsed by the master, or all responses that may be sent by a slave.

Note: Both the Request Function Code and the Response Function Code are in decimal.

Code	Description
1	Read
2	Write
3	Select
4	Operate
5	Direct operate
6	Direct operate, no acknowledgment
20	Enable unsolicited responses
21	Disable unsolicited responses
25	Open file
26	Close file
27	Delete file
28	Get file information
29	Authenticate file
30	Abort file transfer
31	Activate configuration
32	Authentication request
129	Response
130	Unsolicited response
131	Authentication response

Note: Both the Request Qualifier Code and the Response Qualifier Code are in hexadecimal.

Code	Description
00	8-bit start-stop
01	16-bit start-stop
06	No range, or all
07	8-bit limited quantity
08	16-bit limited quantity
17	8-bit index
18	16-bit index
5B	Free format

Object Group 0 - Device Attributes

Variation	Description	Request Function Code	Request Qualifier Codes	Response Function Codes	Response Qualifier Codes
1-253	Standard Set 0 and User Defined Sets	1 2	00, 06 00	129 N/A	00, 17 N/A
254	Non-specific all attributes request	1	00, 06	129	00, 17
255	List of attribute variations	1	00, 06	129	00, 5B

Object Group 1 - Binary Inputs

Variation	Description	Request Function Code	Request Qualifier Codes	Response Function Codes	Response Qualifier Codes
0	Any variation	1	00, 01, 06	N/A	N/A
1	Packed format	1	00, 01, 06	129	00, 01
2	With flags	1	00, 01, 06	129	00, 01

Object Group 2 - Binary Input Event

Variation	Description	Request Function Code	Request Qualifier Codes	Response Function Codes	Response Qualifier Codes
0	Any variation	N/A	N/A	N/A	N/A
1	Without time	N/A	N/A	129, 130	17, 28
2	With absolute time	N/A	N/A	129, 130	17, 28
3	With relative time	N/A	N/A	129, 130	17, 28

Object Group 3 - Double-Bit Inputs

Variation	Description	Request Function Code	Request Qualifier Codes	Response Function Codes	Response Qualifier Codes
0	Any variation	1	00, 01, 06	N/A	N/A
1	Packed format	1	00, 01, 06	129	00, 01
2	With flags	1	00, 01, 06	129	00, 01

Object Group 4 - Double-Bit Binary Input Event

Variation	Description	Request Function Code	Request Qualifier Codes	Response Function Codes	Response Qualifier Codes
0	Any variation	N/A	N/A	N/A	N/A
1	Without time	N/A	N/A	129, 130	17, 28
2	With absolute time	N/A	N/A	129, 130	17, 28
3	With relative time	N/A	N/A	129, 130	17, 28

Object Group 10 - Binary Outputs

Variation	Description	Request Function Code	Request Qualifier Codes	Response Function Codes	Response Qualifier Codes
0	Any variation	1	00, 01, 06	N/A	N/A
1	Packed format	1	00, 01, 06	129	00, 01
2	Output status with flags	1	00, 01, 06	129	00, 01

Object Group 11 - Binary Output Event

Variation	Description	Request Function Code	Request Qualifier Codes	Response Function Codes	Response Qualifier Codes
0	Any variation	N/A	N/A	N/A	N/A
1	Status without time	N/A	N/A	129, 130	17, 28
2	Status with time	N/A	N/A	129, 130	17, 28

Object Group 12 - Binary Command

Variation	Description	Request Function Code	Request Qualifier Codes	Response Function Codes	Response Qualifier Codes
1	Control Relay Output Block (CROB)	3, 4, 5, 6	17, 28	129	Echo of request

Object Group 20 - Counters

Variation	Description	Request Function Code	Request Qualifier Codes	Response Function Codes	Response Qualifier Codes
0	Any variation	1	00, 01, 06	N/A	N/A
1	32-bit with flag	1	00, 01, 06	129	00, 01
2	16-bit with flag	1	00, 01 06	129	00, 01
5	32-bit without flag	1	00, 01 06	129	00, 01
6	16-bit without flag	1	00, 01 06	129	00, 01

Object Group 21 - Frozen Counters

Variation	Description	Request Function Code	Request Qualifier Codes	Response Function Codes	Response Qualifier Codes
0	Any variation	1	00, 01, 06	N/A	N/A
1	32-bit with flag	1	00, 01, 06	129	00, 01
2	16-bit with flag	1	00, 01, 06	129	00, 01
5	32-bit with flag and time	1	00, 01, 06	129	00, 01
6	16-bit with flag and time	1	00, 01, 06	129	00, 01
9	32-bit without flag	1	00, 01 06	129	00, 01
10	16-bit without flag	1	00, 01 06	129	00, 01

Object Group 22 - Counter Event

Variation	Description	Request Function Code	Request Qualifier Codes	Response Function Codes	Response Qualifier Codes
0	Any variation	N/A	N/A	N/A	N/A
1	32-bit with flag	N/A	N/A	129, 130	17, 28
2	16-bit with flag	N/A	N/A	129, 130	17, 28
5	32-bit with flag and time	N/A	N/A	129, 130	17, 28
6	16-bit with flag and time	N/A	N/A	129, 130	17, 28

Object Group 23 - Frozen Counter Event

Variation	Description	Request Function Code	Request Qualifier Codes	Response Function Codes	Response Qualifier Codes
0	Any variation	N/A	N/A	N/A	N/A
1	32-bit with flag	N/A	N/A	129, 130	17, 28
2	16-bit with flag	N/A	N/A	129, 130	17, 28
5	32-bit with flag and time	N/A	N/A	129, 130	17, 28
6	16-bit with flag and time	N/A	N/A	129, 130	17, 28

Object Group 30 - Analog Inputs

Variation	Description	Request Function Code	Request Qualifier Codes	Response Function Codes	Response Qualifier Codes
0	Any variation	1	00, 01, 06	N/A	N/A
1	32-bit with flag	1	00, 01, 06	129	00, 01
2	16-bit with flag	1	00, 01, 06	129	00, 01
3	32-bit without flag	1	00, 01, 06	129	00, 01

Variation	Description	Request Function Code	Request Qualifier Codes	Response Function Codes	Response Qualifier Codes
4	16-bit without flag	1	00, 01, 06	129	00, 01
5	Single-precision floating-point with flag	1	00, 01, 06	129	00, 01
6	Double-precision floating-point with flag	1	00, 01, 06	129	00, 01

Object Group 32 - Analog Input Event

Variation	Description	Request Function Code	Request Qualifier Codes	Response Function Codes	Response Qualifier Codes
0	Any variation	N/A	N/A	N/A	N/A
1	32-bit without time	N/A	N/A	129, 130	17, 28
2	16-bit without time	N/A	N/A	129, 130	17, 28
3	32-bit with time	N/A	N/A	129, 130	17, 28
4	16-bit with time	N/A	N/A	129, 130	17, 28
5	Single-precision floating-point without time	N/A	N/A	129, 130	17, 28
6	Double-precision floating-point without time	N/A	N/A	129, 130	17, 28
7	Single-precision floating-point with time	N/A	N/A	129, 130	17, 28
8	Double-precision floating-point with time	N/A	N/A	129, 130	17, 28

Object Group 34 - Analog Inputs Deadband

Variation	Description	Request Function Code	Request Qualifier Codes	Response Function Codes	Response Qualifier Codes
0	Any variation	1	00, 01, 06	N/A	N/A
1	16-bit	1	00, 01, 06	129	00, 01
		2	00, 01	N/A	N/A
2	32-bit	1	00, 01, 06	129	00, 01
		2	00, 01	N/A	N/A
3	Single-precision floating-point	1	00, 01, 06	129	00, 01
		2	00, 01	N/A	N/A

Object Group 40 - Analog Outputs

Variation	Description	Request Function Code	Request Qualifier Codes	Response Function Codes	Response Qualifier Codes
0	Any variation	1	00, 01, 06	N/A	N/A
1	32-bit with flag	1	00, 01, 06	129	00, 01
2	16-bit with flag	1	00, 01, 06	129	00, 01
3	Single-precision floating-point with flag	1	00, 01, 06	129	00, 01
4	Double-precision floating-point with flag	1	00, 01, 06	129	00, 01

Object Group 41 - Analog Output Status

Variation	Description	Request Function Code	Request Qualifier Codes	Response Function Codes	Response Qualifier Codes
1	32-bit	3, 4, 5, 6	17, 28	129	Echo of request
2	16-bit	3, 4, 5, 6	17, 28	129	Echo of request
3	Single-precision floating-point	3, 4, 5, 6	17, 28	129	Echo of request

Variation	Description	Request Function Code	Request Qualifier Codes	Response Function Codes	Response Qualifier Codes
4	Double-precision floating-point	3, 4, 5, 6	17, 28	129	Echo of request

Object Group 42 - Analog Output Event

Variation	Description	Request Function Code	Request Qualifier Codes	Response Function Codes	Response Qualifier Codes
0	Any variation	N/A	N/A	N/A	N/A
1	32-bit without time	N/A	N/A	129, 130	17, 28
2	16-bit without time	N/A	N/A	129, 130	17, 28
3	32-bit with time	N/A	N/A	129, 130	17, 28
4	16-bit with time	N/A	N/A	129, 130	17, 28
5	Single-precision floating-point without time	N/A	N/A	129, 130	17, 28
6	Double-precision floating-point without time	N/A	N/A	129, 130	17, 28
7	Single-precision floating-point with time	N/A	N/A	129, 130	17, 28
8	Double-precision floating-point with time	N/A	N/A	129, 130	17, 28

Object Group 50 - Time and Date

Variation	Description	Request Function Code	Request Qualifier Codes	Response Function Codes	Response Qualifier Codes
1	Absolute time	1 2	07 07	129 N/A	07 N/A
3	Absolute time at last recorded time	2	07	N/A	N/A

Object Group 51 - Time and Date CTO

Variation	Description	Request Function Code	Request Qualifier Codes	Response Function Codes	Response Qualifier Codes
1	Absolute time, synchronized	N/A	N/A	129, 130	07
2	Absolute time, unsynchronized	N/A	N/A	129, 130	07

Object Group 52 - Time Delay

Variation	Description	Request Function Code	Request Qualifier Codes	Response Function Codes	Response Qualifier Codes
1	Coarse	N/A	N/A	129	07
2	Fine	N/A	N/A	129	07

Object Group 60 - Class Poll Data Request

Variation	Description	Request Function Code	Request Qualifier Codes	Response Function Code	Response Qualifier Codes
1	Class 0 data	1	06	N/A	N/A
2	Class 1 data	1 20 21	06, 07, 08 06 06	N/A N/A N/A	N/A N/A N/A
3	Class 2 data	1 20 21	06, 07, 08 06 06	N/A N/A N/A	N/A N/A N/A

Variation	Description	Request Function Code	Request Qualifier Codes	Response Function Code	Response Qualifier Codes
4	Class 3 data	1 20 21	06, 07, 08 06 06	N/A N/A N/A	N/A N/A N/A

Object Group 70 - File Identifiers

Variation	Description	Request Function Code	Request Qualifier Codes	Response Function Codes	Response Qualifier Codes
2	Authentication	29	5B	129	5B
3	File command	25, 27	5B	N/A	N/A
4	File command status	26, 30 N/A	5B N/A	129 130	5B 5B
5	File transport	1, 2 N/A	5B N/A	129 130	5B 5B
6	File transport status	1 N/A	5B N/A	129 130	5B 5B
7	File descriptor	28 N/A	5B N/A	129 130	5B 5B
8	File specification string	31	5B	N/A	N/A

Object Group 80 - Internal Indications

Variation	Description	Request Function Code	Request Qualifier Codes	Response Function Codes	Response Qualifier Codes
1	Packed format	1	00, 01	129	00, 01

Object Group 85 - Data Set Prototype

Variation	Description	Request Function Code	Request Qualifier Codes	Response Function Codes	Response Qualifier Codes
1	With UUID	1	06	129	5B

Object Group 86 - Data Set Descriptor

Variation	Description	Request Function Code	Request Qualifier Codes	Response Function Codes	Response Qualifier Codes
1	Data set contents	1	06	129	5B

Object Group 87 - Data Set Present Value

Variation	Description	Request Function Code	Request Qualifier Codes	Response Function Codes	Response Qualifier Codes
1	Present Value	1 2	00, 01, 06 00, 01	129 N/A	5B N/A

Object Group 88 - Data Set Snapshot

Variation	Description	Request Function Code	Request Qualifier Codes	Response Function Codes	Response Qualifier Codes
1	Data Set Snapshot	N/A	N/A	129, 130	5B

Object Group 110 - Octet String Object

Variation	Description	Request Function Code	Request Qualifier Codes	Response Function Codes	Response Qualifier Codes
1	String	1	00, 01, 06	129	00, 01

Object Group 120 - Authentication Object

Variation	Description	Request Function Code	Request Qualifier Codes	Response Function Codes	Response Qualifier Codes
1	Challenge	32	5B	131	5B
2	Reply	32	5B	131	5B
3	Aggressive Mode Request	1, 2, 3, 4, 5, 6, 20, 21	07	N/A	N/A
4	Session Key Status Request	32	07	N/A	N/A
5	Session Key Status	N/A	N/A	131	5B
6	Session Key Change	32	5B	N/A	N/A
7	Error	32	5B	131	5B
9	HMAC	32	5B	N/A	N/A

Index

A

Added <tag count> Data Set tag(s). 58
Address <address> is not valid on device <channel> <device>. 51
Address <address> is out of range for the specified device or register. 51
Address Descriptions 25
Address Validation 51
Application Layer 90
Authentication 17
Authentication Error Messages 52
Automatic Tag Database Generation Messages 55

C

Channel Setup 9
Communications 10

D

Data set write of value <value to be written> pending on tag address <address> on device <device>. 58
Data type <type> is not valid for device address <address>. 51
Data Types Description 24
Device - Advanced 21
Device <device name> is not responding. 60
Device <device> does not support the LAN Time Sync Style Record Current Time Function Code 24. 58
Device <device> does not support the LAN Time Sync Style write to object group 50, variation 3. 58
Device <device> indicated an event buffer overflow (IIN 2.3). 59
Device <device> indicated it restarted (IIN 1.7). 59
Device <device> initialization completed. 59
Device <device> requested time synchronization (IIN 1.4). 60
Device <device> restarting. 60
Device address <address> contains a syntax error. 51
Device address <address> is read only. 52
Device Identification 88
Device Profile 88
Device Setup 10
Device Status Messages 56
DNP Specific Error Messages 64
DWord 24

E

Error Descriptions 51

Event Playback 15

F

File Control 19

File Control Error Messages 83

File transfer failure on device <device> for file index <index>. Local file <file name> is empty. 85

File transfer failure on device <device> for file index <index>. Device returned File-Related Status Code <status code> - <description>. 84

File transfer failure on device <device> for file index <index>. File size of <size> kilobytes is greater than maximum file size of <maximum size> kilobytes. 84

File transfer failure on device <device> for file index <index>. File transfer aborted by user. 84

File transfer failure on device <device> for file index <index>. File transfer aborted due to communications issue. 85

File transfer failure on device <device> for file index <index>. Local file open failure. <local file open failure>. 85

File transfer failure on device <device> for file index <index>. Session shutting down or duplicate request. 86

H

Help Contents 8

I

Implementation Tables 93

Internal Tags 49

Invalid local file for File Index 70.<file index>, general error. 86

Invalid local file for File Index 70.<file index>, verify the specified path is write-enabled. 86

Invalid local file path for File Index 70.<file index>. 86

Invalid local file syntax for File Index 70.<file index>. 86

Item description on device <device> has been auto-demoted. 57

Item description on device <device> has been auto-promoted to determine if it can be completed. 57

L

Link Layer 90

M

Masters Only 91
Modem Setup 23

O

Object Group 0 - Device Attributes 27
Object Group 1 - Binary Inputs 28
Object Group 10 - Binary Outputs 31
Object Group 110 - Octet String Object 46
Object Group 12 - Binary Output Commands 33
Object Group 120 - Authentication Object 47
Object Group 20 - Counters 35
Object Group 21 - Frozen Counters 36
Object Group 3 - Double-Bit Inputs 30
Object Group 30 - Analog Inputs 37
Object Group 34 - Analog Inputs Deadband 39
Object Group 40 - Analog Outputs 40
Object Group 41 - Analog Output Commands 42
Object Group 50 - Time and Date 42
Object Group 60 - Class Poll Data Request 43
Object Group 70 - File Identifiers 44
Object Group 80 - Internal Indications 44
Object Group 87 - Data Sets 45
Other Object Groups 48
Overview 8

P

Polling 13

R

Reached Max. Events Per Point for object group <object group> Point <data index> on device <device>. 60
Read Errors 64
Request failed on device <device>. Device does not support the function code (IIN2.0). 61
Request to enable unsolicited messaging failed on device <device>. 61

S

Secure authentication failure on device <channel.device>. Aggressive Mode response indicates improper authentication. 53

Secure authentication failure on device <channel.device>. Challenge Reply indicates improper authentication. 53

Secure authentication failure on device <channel.device>. Device does not support the function code (IIN2.0). 52

Secure authentication failure on device <channel.device>. Key Status Request communications failure. Session keys are not valid. 52

Secure authentication failure on device <channel.device>. Key Status Request non-authentic. Session keys are not valid. 53

Secure authentication failure on device <channel.device>. User= <user number>, AssocID= <Association ID>, Sequence= <sequence number>. RX Error Code= <error code>-<error description>. 53

Secure authentication failure on device <channel.device>. User= <user number>, AssocID= <Association ID>, Sequence= <sequence number>. TX Error Code= <error code>-<error description>. 54

Secure authentication failure on device <device>. Key Status Request response status code: <status code>. 55

Security Parameters 91

Special Tags 50

T

Tag Import 16

The returned value for tag address <tag address> in device <device name> has a length of zero. The tag value cannot be set. 66

The returned value of <date returned value> for tag address <address> in device <device> is invalid for the <data type> tag data type. 66

The returned value of <returned numeric value> for tag address <address> in device <device> is invalid for the <data type> tag data type. 66

The returned value of <returned numeric value> for tag address <address> in device <device> is out of range for the <data type> tag data type. 66

The returned value of <returned string value> for tag address <address> in device <device> is invalid for the <data type> tag data type. 66

Timing 9

Timing and Other Considerations 22

U

Unable to add data set <data set index> on device <device name>. Data set has <number of elements> elements. The maximum number of elements allowed is <max. elements>. 55

Unable to bind to local address (IP: xxx.xxx.xxx.xxx, Source Port: x). 62

Unable to generate a tag database for device <device name>. Unable to open communications port. 56

Unable to generate a tag database for device <device>. Channel is not open. 55

Unable to generate a tag database for device <device>. Session is not open. 55

Unable to generate a tag database for device <driver>. The device is not responding. 56

Unable to read device attribute set <set number>. No tags added on device <device>. 56

Unable to read point(s) <OBJ.VAR.IDX - OBJ.VAR.IDX> on device <device>. Unable to receive response from device <device> within timeout. Either the request or response could not be completed or the response is invalid. 71

Unable to read point(s) <OBJ.VAR.IDX - OBJ.VAR.IDX> on device <device>. An abnormal condition exists in the device (IIN1.6). 69

Unable to read point(s) <OBJ.VAR.IDX - OBJ.VAR.IDX> on device <device>. Device detected corrupt configuration (IIN2.5). 69

- Unable to read point(s) <OBJ.VAR.IDX – OBJ.VAR.IDX> on device <device>. Device does not support a point in the range or other parameter error (IIN2.2). 70
- Unable to read point(s) <OBJ.VAR.IDX – OBJ.VAR.IDX> on device <device>. Device does not support requested operation for objects in the request (IIN2.1). 70
- Unable to read point(s) <OBJ.VAR.IDX – OBJ.VAR.IDX> on device <device>. Device does not support the function code (IIN2.0). 70
- Unable to read point(s) <OBJ.VAR.IDX – OBJ.VAR.IDX> on device <device>. Device reports that some output points are in local mode (IIN1.5). 70
- Unable to read point(s) <OBJ.VAR.IDX – OBJ.VAR.IDX> on device <device>. Device reports that the operation is already executing (IIN2.4). 70
- Unable to read point(s) <OBJ.VAR.IDX – OBJ.VAR.IDX> on device <device>. Failed to initialize communication stack. 62
- Unable to read point(s) <OBJ.VAR.IDX – OBJ.VAR.IDX> on device <device>. Internal error occurred. 62
- Unable to read point(s) <OBJ.VAR.IDX – OBJ.VAR.IDX> on device <device>. Session shutting down or duplicate request. 71
- Unable to read point(s) <OBJ.VAR.IDX – OBJ.VAR.IDX> on device <device>. Unrecognized object returned in response. 71
- Unable to read point(s) <OBJ.VAR.IDX> on device <device>. An abnormal condition exists in the device (IIN1.6). 67
- Unable to read point(s) <OBJ.VAR.IDX> on device <device>. Device detected corrupt configuration (IIN2.5). 67
- Unable to read point(s) <OBJ.VAR.IDX> on device <device>. Device does not support a point in the range or other parameter error (IIN2.2). 67
- Unable to read point(s) <OBJ.VAR.IDX> on device <device>. Device does not support requested operation for objects in the request (IIN2.1). 67
- Unable to read point(s) <OBJ.VAR.IDX> on device <device>. Device does not support the function code (IIN2.0). 67
- Unable to read point(s) <OBJ.VAR.IDX> on device <device>. Device reports that some output points are in local mode (IIN1.5). 68
- Unable to read point(s) <OBJ.VAR.IDX> on device <device>. Device reports that the operation is already executing (IIN2.4). 68
- Unable to read point(s) <OBJ.VAR.IDX> on device <device>. Failed to initialize communication stack. 62
- Unable to read point(s) <OBJ.VAR.IDX> on device <device>. Internal error occurred. 62
- Unable to read point(s) <OBJ.VAR.IDX> on device <device>. Session shutting down or duplicate request. 68
- Unable to read point(s) <OBJ.VAR.IDX> on device <device>. Unable to receive response from device <device> within timeout. Either the request or response could not be completed or the response is invalid. 68
- Unable to read point(s) <OBJ.VAR.IDX> on device <device>. Unrecognized object returned in response. 69
- Unable to read set <set index> of object group <object group> on device <device>. An abnormal condition exists in the device (IIN1.6). 72
- Unable to read set <set index> of object group <object group> on device <device>. Device detected corrupt configuration (IIN2.5). 72
- Unable to read set <set index> of object group <object group> on device <device>. Device does not support a point in the range or other parameter error (IIN2.2). 72
- Unable to read set <set index> of object group <object group> on device <device>. Device does not support requested operation for objects in the request (IIN2.1). 72
- Unable to read set <set index> of object group <object group> on device <device>. Device does not support the function code (IIN2.0). 72
- Unable to read set <set index> of object group <object group> on device <device>. Device reports that some output points are in local mode (IIN1.5). 73
- Unable to read set <set index> of object group <object group> on device <device>. Device reports that the operation is already executing (IIN2.4). 73
- Unable to read set <set index> of object group <object group> on device <device>. Session shutting down or duplicate request. 73

- Unable to read set <set index> of object group <object group> on device <device>. Unrecognized object returned in response. 73
- Unable to read tag <tag address> on device <device>. Device indicates one or more exception conditions (DNP flags byte=<hexadecimal byte> - <DNP flag exception list'). 63
- Unable to read tag address <address> on device <device>. Element index <variation> is not defined in data set <index>. 74
- Unable to read tag address <address> on device <device>. No definition for data set <index>. 74
- Unable to read tag address <address> on device <device>. Response missing data. 74
- Unable to receive response from device <device> within timeout. Either the request or response could not be completed or the response is invalid. 63
- Unable to write to address <address> on device <device>. Internal error occurred. 64
- Unable to write to address <address> on device <device>. Activate Configuration-Related Status Code <status code> - <description>. 76
- Unable to write to address <address> on device <device>. An abnormal condition exists in the device (IIN1.6). 76
- Unable to write to address <address> on device <device>. Channel Response Timeout must be between <min. channel response timeout> and <max. channel response timeout>. 76
- Unable to write to address <address> on device <device>. Control-Related Status Code <status code>. 76
- Unable to write to address <address> on device <device>. Device detected corrupt configuration (IIN2.5). 77
- Unable to write to address <address> on device <device>. Device does not support a point in the range or other parameter error (IIN2.2). 77
- Unable to write to address <address> on device <device>. Device does not support requested operation for objects in the request (IIN2.1). 78
- Unable to write to address <address> on device <device>. Device does not support the function code (IIN2.0). 78
- Unable to write to address <address> on device <device>. Device reports that some output points are in local mode (IIN1.5). 78
- Unable to write to address <address> on device <device>. Device reports that the operation is already executing (IIN2.4). 78
- Unable to write to address <address> on device <device>. Device Request Timeout must be between <min. value> and <max. value>. 78
- Unable to write to address <address> on device <device>. Element index <variation> is not defined in data set <index>. 79
- Unable to write to address <address> on device <device>. Event Poll Interval must be between <min. value> and <max. value>. 79
- Unable to write to address <address> on device <device>. Failed to initialize communication stack. 64
- Unable to write to address <address> on device <device>. File name writes have been disabled. 79
- Unable to write to address <address> on device <device>. Integrity Poll Interval must be between <min. value> and <max. value>. 79
- Unable to write to address <address> on device <device>. Master address <master address> already in use as slave address on device <device>. 80
- Unable to write to address <address> on device <device>. Master address must be between <min. master address> and <max. master address>. 80
- Unable to write to address <address> on device <device>. Master and slave address cannot be the same. 80
- Unable to write to address <address> on device <device>. No definition for data set <index>. 80
- Unable to write to address <address> on device <device>. Select operate response invalid. 80
- Unable to write to address <address> on device <device>. Session shutting down or duplicate request. 81
- Unable to write to address <address> on device <device>. Slave address <slave address> already in use on device <device>. 81
- Unable to write to address <address> on device <device>. Slave address must be between <min. slave address> and <max. slave address>. 81
- Unable to write to address <address> on device <device>. Tag <data type> data type is incompatible with

the data set element <data type> data type. 81

Unable to write to address <address> on device <device>. Unable to receive response from device <device> within timeout. Either the request or response could not be completed or the response is invalid. 81

Unable to write to address <address> on device <device>. Unrecognized object returned in response. 82

Unable to write to address <address> on device <device>. Unsupported operation type. 82

Unable to write to address <address> on device <device>. Unsupported Trip-Close Code. 82

Unable to write to address <address> on device <device>. Write value specified is invalid or incomplete. 83

Unsolicited Messaging 14

W

Write complete to data set <index> on device <device>. 64

Write Errors 75